

GIOBAGNARA

ALL NEWS

GIOBAGNARA
HANDMADE IN ITALY

GLENN SESTIG
x
GIOBAGNARA

PIGMENT
FRANCE
by GIOBAGNARA

FRANCESCO BALZANO
x
GIOBAGNARA

RABITTI
1969
by GIOBAGNARA

RUDI
finest regenerated leather
HANDMADE IN ITALY

STEPHANE PARMENTIER
x
GIOBAGNARA

GIOBAGNARA

UPDATE

FEBRUARY 2021 — SEPTEMBER 2020



GIORGIO BAGNARA, FOUNDER AND CEO OF GIOBAGNARA

Born into a family renowned for cultivating for three generations the art of living, Giorgio Bagnara became passionate about his calling at a very early age. In the late Nineties, after noticing that leather from the fashion industry was not considered enough as material for home accessories, he founded GIOBAGNARA with the goal of applying it to a complete collection. Along with his wife, Vanessa, he decided to move his design studios and workshops in the old docks of the Port of Genoa where, surrounded by the essence and beauty of that location, the company took a significant step forward.

GIOBAGNARA

Renowned for its elegant creations that convey luxury without ostentation, GIOBAGNARA adheres to the highest standards of craftsmanship. By pursuing a philosophy that incorporates traditional know-how with leading-edge technologies, and offering a limitless color palette of quality leathers and suede, founder Giorgio Bagnara has been able to experiment and push the technical boundaries of his craft in order to create pieces that are both beautiful and functional.

Launched in 1999, the GIOBAGNARA brand has quickly earned a reputation for expert leather workmanship, and its founder has become a key partner for a large number of interior designers as well as a select group of yacht and private jet designers who rely on his specialized knowledge to realize made-to-measure commissions.

In 2015, Giorgio Bagnara expanded his leather goods portfolio with the acquisition of saddle leather specialist RABITTI1969.

In 2017, Bagnara initiated a collaboration with French designer Stéphane Parmentier, who was appointed creative director of GIOBAGNARA and its affiliate brands.

In 2018, the company's portfolio grew with the strategic acquisition of PIGMENT FRANCE, a respected company with specialized skills in leather covering and the weaving of wicker, rattan and straw.

Today, two decades after its launch, GIOBAGNARA counts more than 60 employees

The brand now boasts an impressive offer of quality leather homewares and is ready to embark on its next exciting chapter.

STRUCTURA TRIPLE GAME BOX CHESS | DRAUGHTS | MUEHLE

Walnut wood structure with sole leather cover featuring an engraved chess and draughts field on one side and a muehle field on the other.

Includes sole leather chess and draughts made in brown (SL09) and natural (SL51) colors.

The box features inner partitions to host the playing pawns.

The design is solid yet light in appearance, while the material projects a vintage look that will age gracefully.

Custom sizes available on request.



VG063

cm 38 x 38 | h. cm 6

Sole leather available colors:
brown (SL09) + natural (SL51).





SOLE LEATHER CHESS PIECES

Sole leather chess pieces
made in brown (SL09)
and natural (SL51) colors.

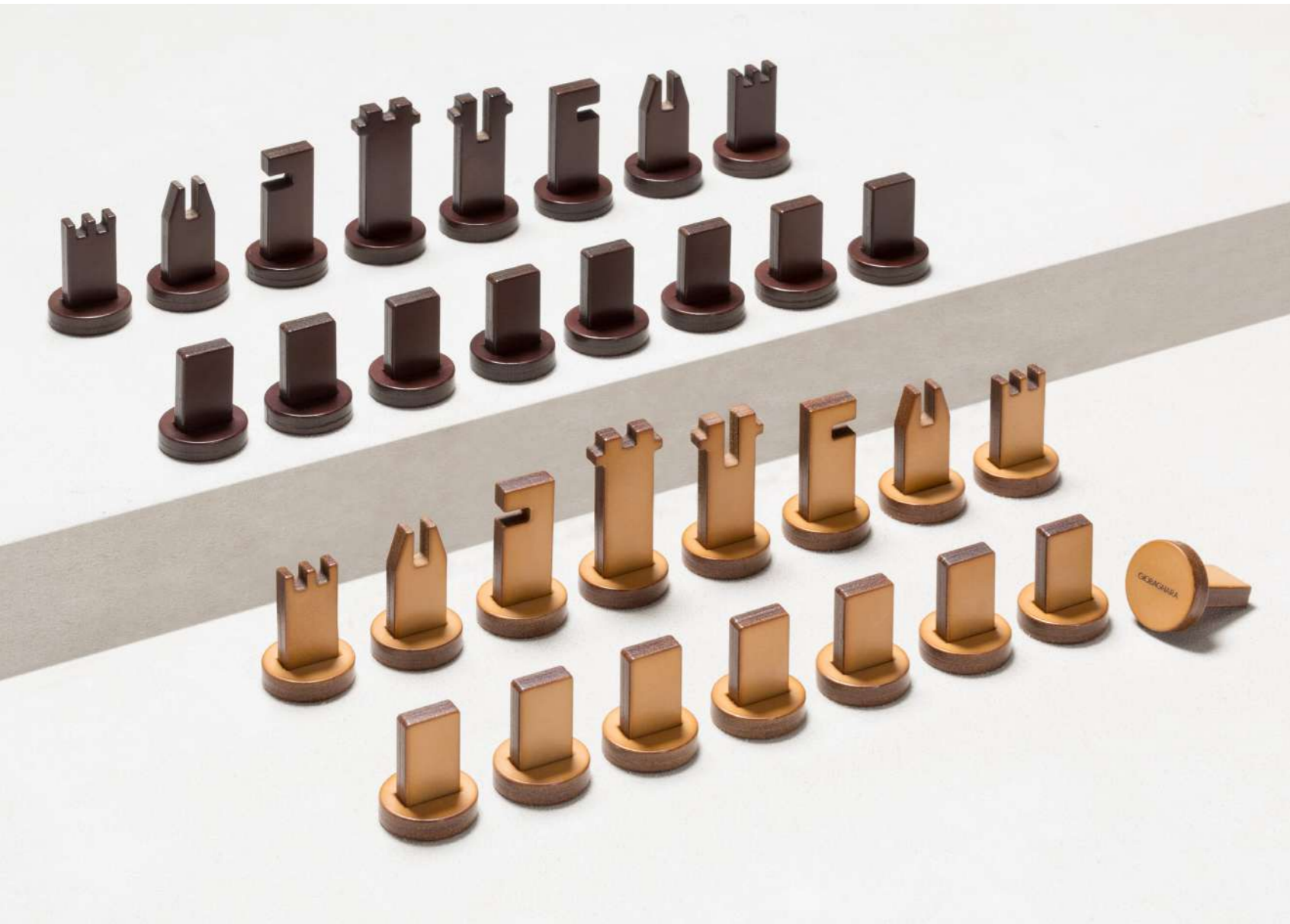

chess pieces refill — VG063RE
each piece is different in size

Sole leather available colors:
brown (SL09) + natural (SL51).

SOLE LEATHER DRAUGHTS PIECES

Sole leather draughts pieces
made in brown (SL09)
and natural (SL51) colors.



x24 draughts pieces — VG064RE
single piece: Ø cm 3 | h. cm 1

x30 draughts pieces — VG065RE
single piece: Ø cm 3 | h. cm 1

Sole leather available colors:
brown (SL09) + natural (SL51).



STRUCTURA RECTANGULAR BOX

Walnut wood structure with sole leather cover featuring an engraved decorative stripe.

The design is solid yet light in appearance, while the material projects a vintage look that will age gracefully.

Custom sizes available on request.



HB231
cm 25 x 15 | h. cm 5.5

Sole leather available colors:
brown (SL09) + natural (SL51).

STRUCTURA
LEATHER & MARBLE
RECTANGULAR BOX

With their minimal formal line enhanced by distinctive "L" shaped corners, these boxes are perfect accessories for any space. The combination of two precious natural materials, such as travertine and the finest Italian leather, generates a perfect aesthetic balance.

Custom sizes available on request.



HB236
cm 25 x 15 | h. cm 5.5





STRUCTURA
MARBLE
RECTANGULAR BOX

With their minimal formal line enhanced by distinctive "L" shaped corners, these boxes are perfect accessories for any space. The use of a precious natural material such as travertine generates unique texture contrasts and motifs.

Custom sizes available on request.



HB231M
cm 25 x 15 | h. cm 5.5

STRUCTURA
LEATHER & MARBLE
LONG RECTANGULAR
VALET TRAY

With their minimal formal line enhanced by distinctive "L" shaped corners, these boxes are perfect accessories for any space. The combination of two precious natural materials, such as travertine and the finest Italian leather, generates a perfect aesthetic balance. Custom sizes available on request.



small — HV256
cm 25 x 15 | h. cm 3

medium — HV257
cm 29.5 x 19.5 | h. cm 3

large — HV258
cm 33.5 x 23.5 | h. cm 3

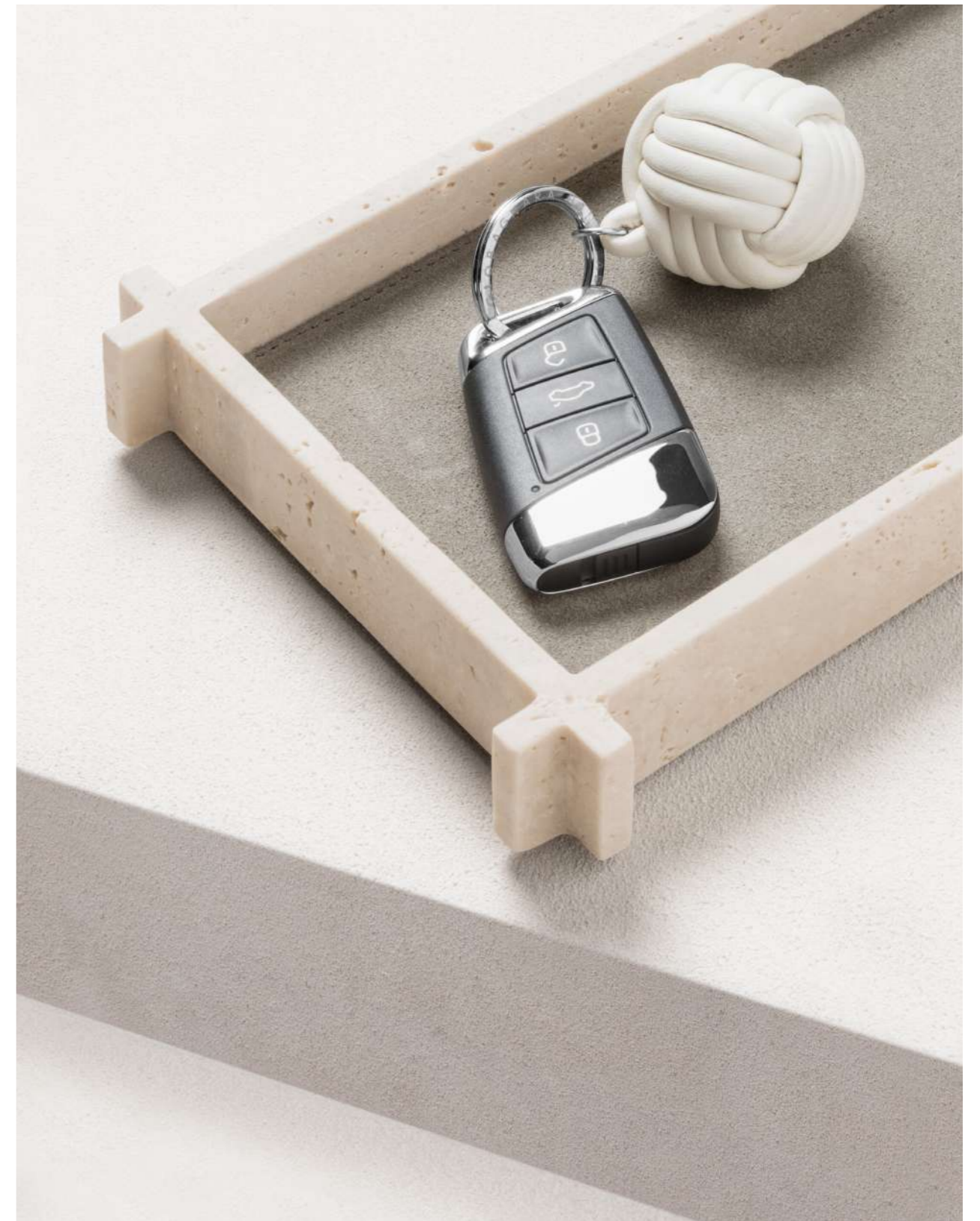

LATINA MARBLE DESK SET

Featuring an absolute minimalist design carved from travertine, the Latina desk set boasts essential sculptural traits and is an elegant modern addition to any office setting with its sophisticated and heavyweight pieces.

Custom sizes available on request.

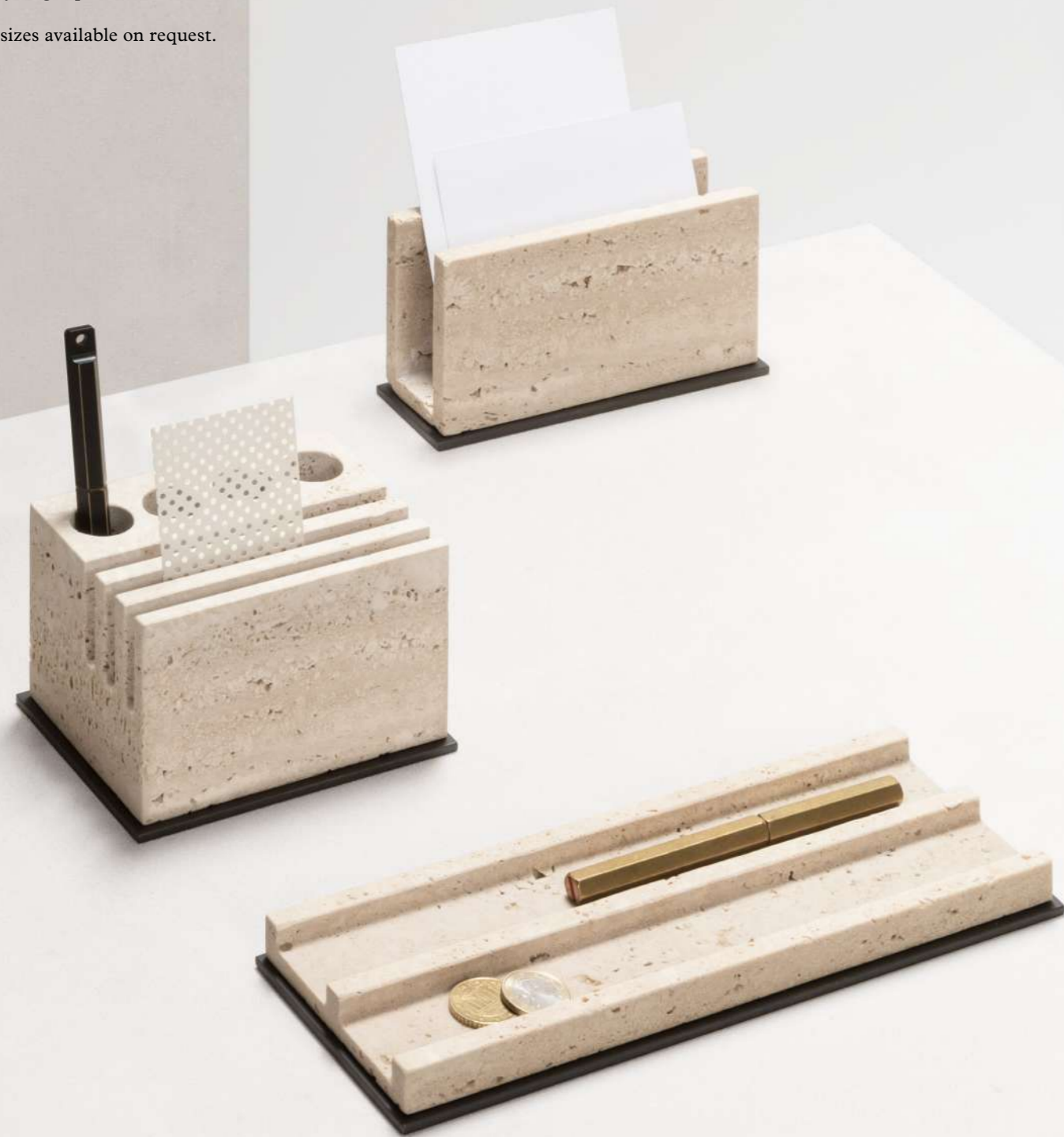

Latina
marble
pen holder
SA710M
cm 12 x 9 | h. cm 8

Travertine structure
with brass base frame
available in different
finishes.
Non-slip waterproof
rubber base underneath.

Metal finishes available:
chrome / bronze / brass.



chrome bronze brass



Latina
marble
envelope holder
SA711M
cm 15 x 4.5 | h. cm 8.5

Travertine structure
with brass base frame
available in different
finishes.
Non-slip waterproof
rubber base underneath.

Metal finishes available:
chrome / bronze / brass.



chrome bronze brass



Latina
marble
valet tray
SA712M
cm 25 x 9 | h. cm 1.5

Travertine structure
with brass base frame
available in different
finishes.
Non-slip waterproof
rubber base underneath.

Metal finishes available:
chrome / bronze / brass.

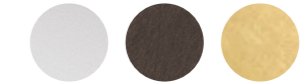

chrome bronze brass

LATINA LEATHER & MARBLE DESK SET

Featuring an absolute minimalist design carved from travertine, the Latina desk set boasts essential sculptural traits and is an elegant modern addition to any office setting with its sophisticated and heavyweight pieces, while the addition of precious leather inserts generates a perfect aesthetic balance.

Custom sizes available on request.



Latina
leather & marble
pen holder
SA715
cm 12 x 9.5 | h. cm 8

Travertine structure with leather inserts and brass base frame available in different finishes. Non-slip waterproof rubber base underneath.

Metal finishes available:
chrome / bronze / brass.



chrome bronze brass



Latina
Leather & marble
envelope holder
SA716
cm 15 x 5 | h. cm 8.5

Travertine structure with leather inserts and brass base frame available in different finishes. Non-slip waterproof rubber base underneath.

Metal finishes available:
chrome / bronze / brass.



chrome bronze brass



Latina
Leather & marble
valet tray
SA717
cm 25 x 9 | h. cm 1.5

Travertine structure with leather inserts and brass base frame available in different finishes. Non-slip waterproof rubber base underneath.

Metal finishes available:
chrome / bronze / brass.



chrome bronze brass

CURZIO DESK SET

The pieces of this collection boast a sharp, geometric design. They are entirely carved from solid metal blocks available in three different finishes (polished chrome, brushed bronze and brushed brass) and feature fine leather inserts.





Curzio ruler
SA701
cm 21 x 3.5 | h. cm 1

This piece boasts carved labels and numbers and has a fixed central bar that grants an easy grip. It features nappa leather underneath to avoid scratches on surfaces.

Metal finishes available:
chrome / bronze / brass.



chrome bronze brass



Curzio triangle ruler
SA702
cm 27.5 x 16 | h. cm 1

This piece boasts carved labels and numbers and has a fixed central bar that grants an easy grip. It features nappa leather underneath to avoid scratches on surfaces.

Metal finishes available:
chrome / bronze / brass.



chrome bronze brass



Curzio pencil sharpener
SA703
cm 6 x 6 | h. cm 6.5

It features nappa leather underneath to avoid scratches on surfaces.

Metal finishes available:
chrome / bronze / brass.

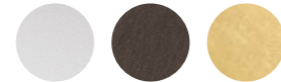

chrome bronze brass



Curzio tape dispenser
SA705
cm 12 x 3.5 | h. cm 7

It features nappa leather underneath to avoid scratches on surfaces.

Metal finishes available:
chrome / bronze / brass.

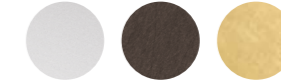

chrome bronze brass



Curzio pen holder
SA706
cm 12 x 5 | h. cm 10

It features nappa leather underneath to avoid scratches on surfaces.

Metal finishes available:
chrome / bronze / brass.

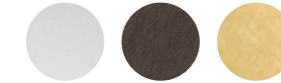

chrome bronze brass



Curzio envelope holder
SA707
cm 15 x 4.5 | h. cm 8

It features nappa leather underneath to avoid scratches on surfaces.

Metal finishes available:
chrome / bronze / brass.

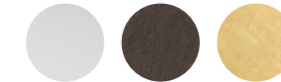

chrome bronze brass



Curzio paper knife
SA704
cm 26.5 x 2 | h. cm 0.5

It features leather inserts
on both sides of the hilt.

Metal finishes available:
chrome / bronze / brass.



chrome bronze brass



Curzio ashtray
VS074
cm 12 x 9.5 | h. cm 2

This piece has a space
for cigars on one side
and for cigarettes on
the other; additional
support is provided
by a fixed central bar.
It features nappa leather
underneath to avoid
scratches on surfaces.

Metal finishes available:
chrome / bronze / brass.



chrome bronze brass



Curzio lighter
VS034
cm 6 x 6 | h. cm 7

It features nappa leather
underneath to avoid
scratches on surfaces.

Metal finishes available:
chrome / bronze / brass.



chrome bronze brass



MAGNUS GYM WEIGHTS SET

Metal structure available in different finishes and provided with leather inserts and walnut wood grip.

Custom sizes available on request.

Metal finishes available:
chrome / bronze / brass.



chrome bronze brass





Magnus
set n°1 (1, 3, 5 kg weights)
PB129
cm 25 x 24 | h. cm 38
base: cm 20 x 24 | h. cm 38

Metal finishes available:
chrome / bronze / brass.



chrome bronze brass



Magnus
set n°2 (2, 4, 6 kg weights)
PB128
cm 27 x 24 | h. cm 42
base: cm 22 x 24 | h. cm 42

Metal finishes available:
chrome / bronze / brass.



chrome bronze brass



1kg weights (set of 2)
PB121
cm 22 x 7 | h. cm 7

Metal finishes available:
chrome / bronze / brass.



chrome bronze brass



4kg weights (set of 2)
PB124
cm 22 x 8 | h. cm 8

Metal finishes available:
chrome / bronze / brass.



chrome bronze brass



Magnus
2kg weights (set of 2)
PB122
cm 22 x 9 | h. cm 9

Metal finishes available:
chrome / bronze / brass.



chrome bronze brass



Magnus
5kg weights (set of 2)
PB125
cm 22 x 10 | h. cm 10

Metal finishes available:
chrome / bronze / brass.



chrome bronze brass



Magnus
3kg weights (set of 2)
PB123
cm 22 x 11 | h. cm 11

Metal finishes available:
chrome / bronze / brass.



chrome bronze brass



Magnus
6kg weights (set of 2)
PB126
cm 22 x 12 | h. cm 12

Metal finishes available:
chrome / bronze / brass.



chrome bronze brass



CHRONOS WATCH WINDER

Leather-covered structure. It is sufficient to apply a slight pressure to detach the rotating part, which is provided with a watch strap extender.

It works with 2 AA batteries.

Multiple rotation settings: clockwise, counterclockwise or alternating.

Chronos operates on a basis of gentle rotation, ensuring a consistent movement over a longer period of time that won't over-wind one's watch.



monochrome — GS023
cm 18 x 12 | h. cm 12.5

bicolor — GS024
cm 18 x 12 | h. cm 12.5



SUPERTUSCAN WINE BOTTLE HOLDER

Leather-covered wood structure.
Ideal for both standars and magnum
sized wine bottles.

Other than being a great display for
one's wine, this article works perfectly
as a decanter: as it more than doubles
the surface in contact with air of the
wine inside the bottle, it favors its
oxygenation, allowing it to breathe
and to trigger the release of more
aromatic compounds.

Custom sizes available on request.



TA067
cm 23 x 11 | h. cm 12



POSITANO MARBLE BOTTLE COASTER

Marble structure featuring a brass base frame.
Non-slip waterproof rubber base underneath.

Marble finishes available:



Metal finishes available:
chrome / bronze / brass.

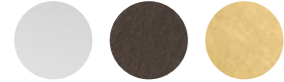

chrome bronze brass



HV591M AR / GU / ER / PO / TR
Ø cm 12 | h. cm 1.5



POSITANO MARBLE BATHROOM SET

The Positano marble bathroom collection boasts metal details with different finishes that enhance each piece of this set, which is now translated in stone.

Every stone used to bring a Positano marble set to life is different from the other, providing a unique, exclusive design to each creation.







Positano marble
soap dispenser
HA269M AR / GU / ER / PO / TR
cm 10 x 7.5 | h. cm 20

Marble structure with brass base frame and spout.
Non-slip waterproof rubber base underneath.

Marble finishes available:



Metal finishes available:
chrome / bronze / brass.



Positano marble
toothbrush holder
HA298M AR / GU / ER / PO / TR
Ø cm 8 | h. cm 13

Marble structure with brass base frame and inner opaque glass. Non-slip waterproof rubber base underneath.

Marble finishes available:



Metal finishes available:
chrome / bronze / brass.



Positano marble
soap bowl
HA293M AR / GU / ER / PO / TR
Ø cm 12 | h. cm 3.5

Marble structure with brass base frame.
Non-slip waterproof rubber base underneath.

Marble finishes available:



Metal finishes available:
chrome / bronze / brass.



Positano marble
round valet tray
small — HV591M AR / GU / ER / PO / TR
Ø cm 12 | h. cm 1.5

Marble structure with brass base frame.
Non-slip waterproof rubber base underneath.

Marble finishes available:



Metal finishes available:
chrome / bronze / brass.



Positano marble
rectangular valet tray
medium — HV582M AR / GU / ER / PO / TR
cm 24 x 18 | h. cm 3.5

Marble structure with brass base frame.
Non-slip waterproof rubber base underneath.

Marble finishes available:



Metal finishes available:
chrome / bronze / brass.



Positano marble
rectangular valet tray
large — HV583M AR / GU / ER / PO / TR
cm 28 x 21 | h. cm 3.5

Marble structure with brass base frame.
Non-slip waterproof rubber base underneath.

Marble finishes available:



Metal finishes available:
chrome / bronze / brass.





Positano marble long rectangular valet tray
small — HV586M AR / GU / ER / PO / TR
cm 26.5 x 10 | h. cm 2

Marble structure with brass base frame.
Non-slip waterproof rubber base underneath.

Marble finishes available:



arabescato white green guatemala eramosa brown black portoro travertino

Metal finishes available:
chrome / bronze / brass.



chrome bronze brass



Positano marble long rectangular valet tray
medium — HV587M AR / GU / ER / PO / TR
cm 31.5 x 12 | h. cm 2

Marble structure with brass base frame.
Non-slip waterproof rubber base underneath.

Marble finishes available:



arabescato white green guatemala eramosa brown black portoro travertino

Metal finishes available:
chrome / bronze / brass.



chrome bronze brass



Positano marble round box
small — HB721M AR / GU / ER / PO / TR
Ø cm 8 | h. cm 13.5

Marble structure with brass base frame and knob.
Non-slip waterproof rubber base underneath.

Marble finishes available:



arabescato white green guatemala eramosa brown black portoro travertino

Metal finishes available:
chrome / bronze / brass.



chrome bronze brass



Positano marble round box
large — HB722M AR / GU / ER / PO / TR
Ø cm 12.5 | h. cm 10.5

Marble structure with brass base frame and knob.
Non-slip waterproof rubber base underneath.

Marble finishes available:



arabescato white green guatemala eramosa brown black portoro travertino

Metal finishes available:
chrome / bronze / brass.



chrome bronze brass



SORRENTO SIDE TABLE

Metal structure available in different finishes boasting a leather top and base.

Metal finishes available:
chrome / bronze / brass.



small — MA056
Ø cm 25 | h. cm 54.5

medium — MA057
Ø cm 30 | h. cm 51.5

large — MA058
Ø cm 35 | h. cm 48.5





SORRENTO MARBLE SIDE TABLE

Metal structure available in different finishes boasting a marble top and base.

Marble finishes available:



arabescato white green guatemala eramosa brown black portoro travertino

Metal finishes available:
chrome / bronze / brass.



chrome bronze brass

small — MA056M
Ø cm 25 | h. cm 54

medium — MA057M
Ø cm 30 | h. cm 51

large — MA058M
Ø cm 35 | h. cm 48





ENEA TABLE LAMP

Leather-covered wood base with a fine linen lampshade.
Being inspired to architectural elements typical of classical antiquity, such as the ancient Greek columns, this lamp boasts fine curves and edges that showcase eye-catching interplays of shadows when lit.



small — LT081
Ø cm 27 | h. cm 43.5
x3 light bulbs E14

large — LT083
Ø cm 36 | h. cm 54.5
x3 light bulbs E14





PERSEUS POUF

Available either in shearling or in travertine, this monolithic pouf boasts elegant curves that perfectly accommodate one's body to ensure comfort.

The main structure is placed on a rotating base and is easy to move due to the smoothness of a high quality teflon cushion, able to sustain any weight up to 300kg.

It is also possible to customize this piece with Customer Fabric.

HS016
57 x 48.5 | h. cm 40.5

marble — HS016M
57 x 48.5 | h. cm 40.5
weight: 60 kg





NEWS PRESENTED IN SEPTEMBER 2020

LUDOVICO TOWEL RACK

Leather-covered wood structure
covered with metal inserts
available in different finishes.

Custom sizes available on request.

Metal finishes available:
chrome / bronze / brass.



chrome bronze brass



BH079
cm 60.5 x 17 | h. cm 89.5



EDOARDO CLOTHES VALET

Wood structure covered with leather,
featuring inserts of finest quality sustainable
cashmere by Fratelli Tallia Di Delfino.
Suit hanger on top that provides optimum
shoulder support.
Provided with a fixed valet tray.

Custom sizes available on request.

Metal finishes available:
chrome / bronze / brass.



chrome bronze brass

Cashmere finishes available:
beige / taupe / dark grey.

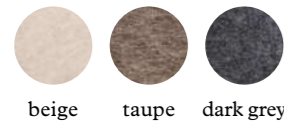

beige taupe dark grey



BH083

cm 45 x 32 | h. cm 99

leather & cashmere — BH084

cm 45 x 32 | h. cm 99



AMEDEO CLOTHES VALET

Leather-covered wood structure
covered with metal inserts
available in different finishes.
Provided with a fixed valet tray.

Custom sizes available on request.

Metal finishes available:
chrome / bronze / brass.



chrome bronze brass



BH085
cm 45.5 x 23.5 | h. cm 109.5

LEATHER COLORS

PRINTED CALFSKIN GOLF

tanned in Italy • origin: Northern Europe • price category: A
waterproof, scratchproof



PRINTED CALFSKIN GOLF

tanned in Italy • origin: Northern Europe • price category: A
waterproof, scratchproof



PRINTED CALFSKIN PANAMA

tanned in Italy • origin: Northern Europe • price category: B
water-resistant, scratchproof



V57
cipress

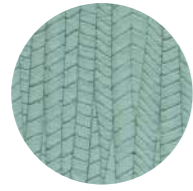

V46
mint

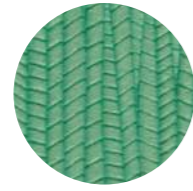

V43
pistachio



V76
mustard



V95
off white

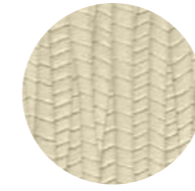

V06
ivory



V91
nude



V42
cappuccino



V51
caramel



V82
rust



V96
clay



V25
moka



V93
plum



V49
ice

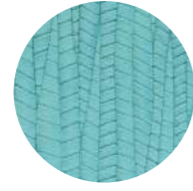

V60
capri



V41
storm grey



V45
dove



V83
stone



V21
mud



V19
graphite



V77
slate



V61
pearl

PRINTED CALFSKIN BELLAGIO

tanned in Italy • origin: Northern Europe • price category: B
water-resistant, scratchproof



X02
loden green



X57
cipress



X76
mustard

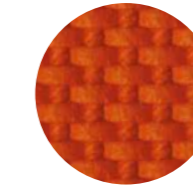

X38
mango



X05
white



X95
off white

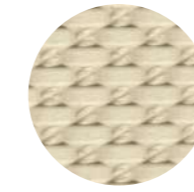

X06
ivory



X91
nude

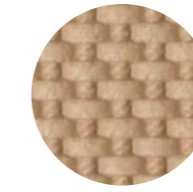

X42
cappuccino



X51
caramel

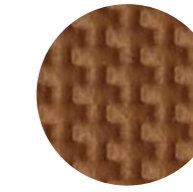

X30
tobacco

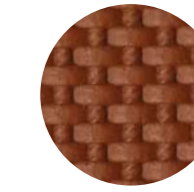

X82
rust



X96
clay



X25
moka



X93
plum



X41
storm grey



X46
mint



X60
capri



X32
ultramarine

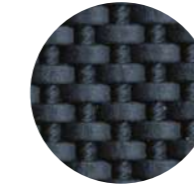

X12
royal blue



X13
red



X45
dove



X83
stone



X37
light grey

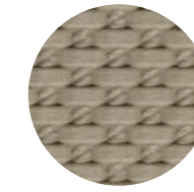

X18
grey

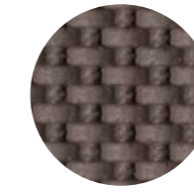

X24
smoke



X67
lava

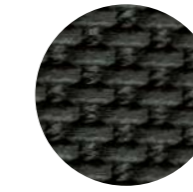

X77
slate



X61
pearl



X63
moonsand



X56
bronze



X58
titanium



X52
silver



X50
gold

PRINTED CALFSKIN CROCODILE

tanned in Italy • origin: Northern Europe • price category: A
waterproof, scratchproof



C02
green



C05
white



C38
mango



C06
ivory



C42
cappuccino



C08
siena



C19
graphite



C41
storm grey



C60
capri



C12
royal blue



C13
red



C17
bordeaux



C37
light grey



C21
mud



C24
smoke



C09
brown



C20
black

PRINTED CALFSKIN SHAGREEN

tanned in Italy • origin: Northern Europe • price category: B
water-resistant and slightly resistant to scratches

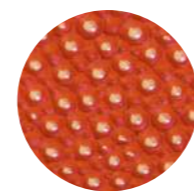

Z38
mango

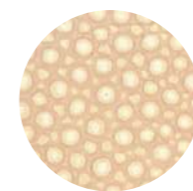

Z06
ivory



Z30
tobacco

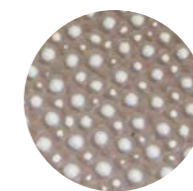

Z96
clay

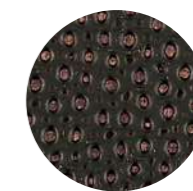

Z25
moka

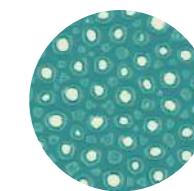

Z10
light blue



Z12
royal blue

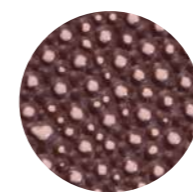

Z17
bordeaux

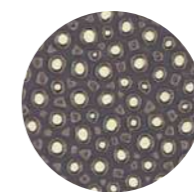

Z21
mud



Z20
black

PRINTED CALFSKIN WILD BOAR

tanned in Italy • origin: Northern Europe • price category: A
waterproof, scratchproof

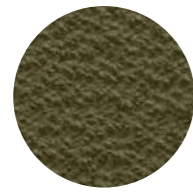

B98
olive green

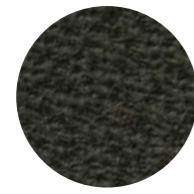

B57
cipress



B01
acid green

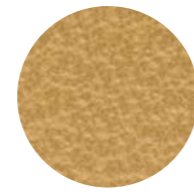

B76
mustard

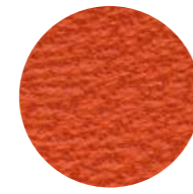

B38
mango



B95
off white



B42
cappuccino

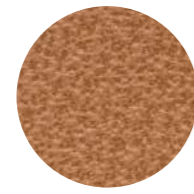

B51
caramel

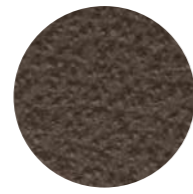

B96
clay

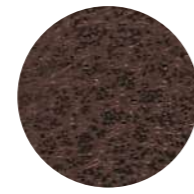

B09
brown



B49
ice

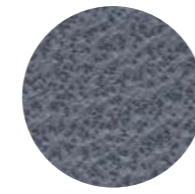

B41
storm grey

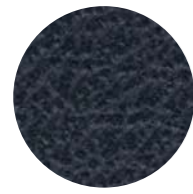

B33
ocean

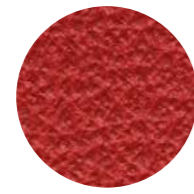

B59
garnet



B17
bordeaux



B83
stone



B37
light grey

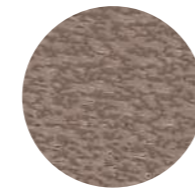

B21
mud



B67
lava



B77
slate



B20
black

PRINTED CALFSKIN WILD DEER

tanned in Italy • origin: Northern Europe • price category: A
water-resistant and slightly resistant to scratches

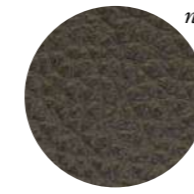

H57
cipress

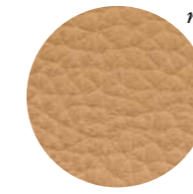

H42
cappuccino



H95
off white



H91
nude

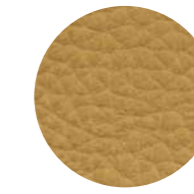

H76
mustard

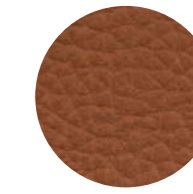

H08
siena

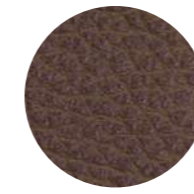

H25
moka

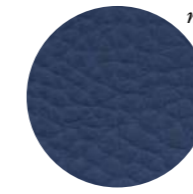

H12
royal blue

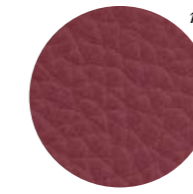

H17
bordeaux



H62
papaya



H24
smoke

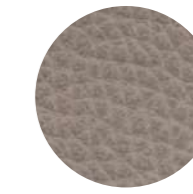

H21
mud

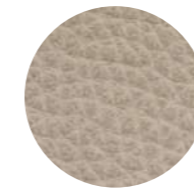

H83
stone



H37
light grey



H67
lava



H93
plum



H20
black

NAPPA

tanned in Italy • origin: Northern Europe • price category: A
water-resistant and slightly resistant to scratches



SUEDE

tanned in Italy • origin: Northern Europe • price category: A
scratchproof



SHEARLING

tanned in Italy • origin: Italy • price category: SHEARLING
not waterproof

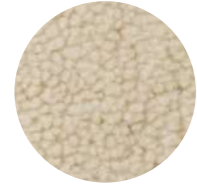

J06
ivory



J25
moka



J37
light grey

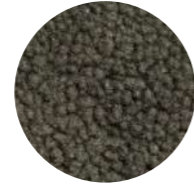

J80
musk

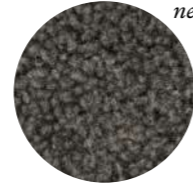

J58
titanium

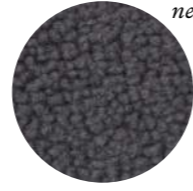

J19
graphite

CALFSKIN PONY

tanned in Italy • origin: Northern Europe • price category: B
waterproof



P80
musk

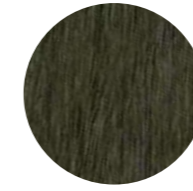

P02
loden green

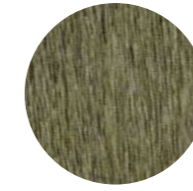

P69
sage



P04
orange



P05
white



P07
sand



P42
cappuccino



P30
tobacco



P09
brown

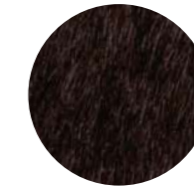

P25
moka

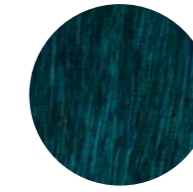

P31
petrol blue



P13
red



P62
papaya



P17
bordeaux



P29
lilac grey

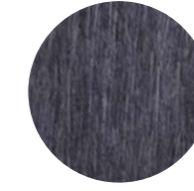

P41
storm grey



P93
plum

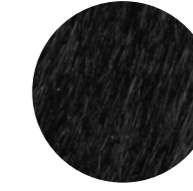

P20
black

REAL SHAGREEN LEATHER

tanned in Italy • origin: Southeast Asia • price category: D
only for jewelry, napkin rings and custom orders

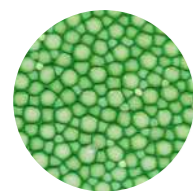

R01
acid green

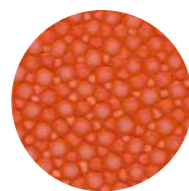

R04
orange



R06
ivory

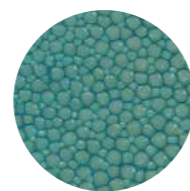

R10
light blue

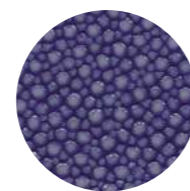

R11
cobalt blue

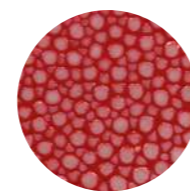

R13
red

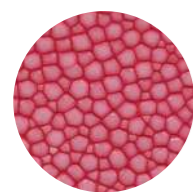

R14
fuchsia

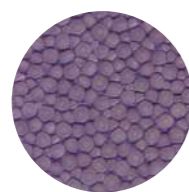

R29
lilac

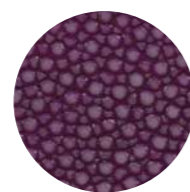

R16
violet



R17
bordeaux

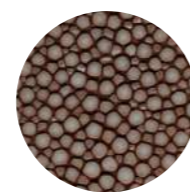

R08
siena

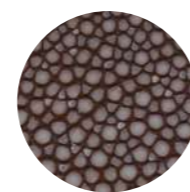

R18
mole brown

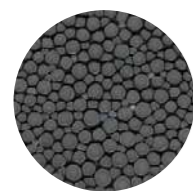

R21
mud

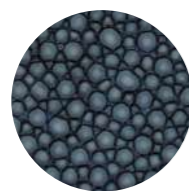

R33
ocean



R20
black

REAL CROCODILE LEATHER

tanned in Italy • origin: South America • price category: D
only for jewelry, napkin rings and custom orders

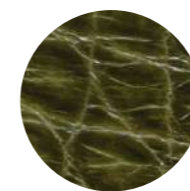

K02
green

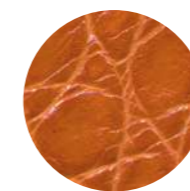

K04
orange

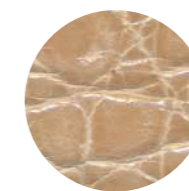

K06
ivory

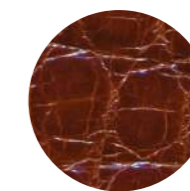

K08
cognac

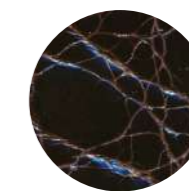

K09
brown



K11
cobalt blue

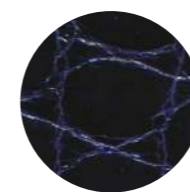

K12
royal blue

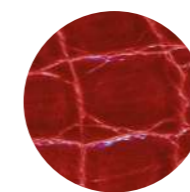

K13
red

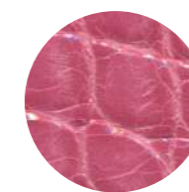

K14
fuchsia

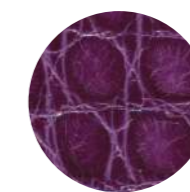

K16
violet

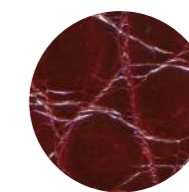

K17
bordeaux

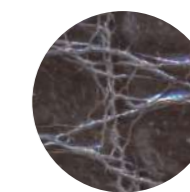

K18
grey

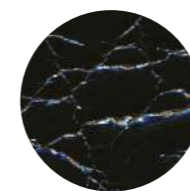

K20
black

SILK-SCREEN PRINTED CALFSKIN PONYLUX



Y81
camouflage

tanned in Italy • origin: Northern Europe • price category: C
calfskin on waterproof, scratchproof

Calf-hair leather with khaki green-colored base featuring a camouflage silkscreen pattern.

PRINTED CALFSKIN LAMIGOLD



M50
lamigold

tanned in Italy • origin: Northern Europe • price category: C
water-resistant, scratchproof

Calfskin featuring a special raised print with gold foil.

PRINTED CALFSKIN CLOUDS



N50
clouds

tanned in Italy • origin: Northern Europe • price category: C
not waterproof

Calfskin with black base and partial gold foil application featuring a unique mottled effect.

PRINTED CALFSKIN FROST



T51
frost

tanned in Italy • origin: Northern Europe • price category: C
water-resistant

Calf skin with metal foil application. It features a pyrite-like appearance and is soft to the touch.

STITCHING

Stitching can be white, tone-on-tone or contrasting color.



DEBOSSSED CUSTOMIZATION

examples of debossed customization
with or without foil (many colors available)

BH200
bespoke | price on request



EMBOSSSED PERSONALIZATION

example of embossed personalization
using lettering or simplified logo.
Lettering size from 11 x 11 mm

BH100
bespoke | price on request



WOOD
METAL
MARBLE

WOOD FINISHES

Choose from 3 standard finishes or inquire about custom options.



WENGE

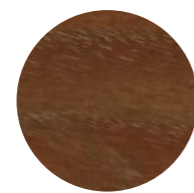

WALNUT



NATURAL

LACQUERED WOOD FINISHES

Choose from 5 standard finishes or inquire about custom options.

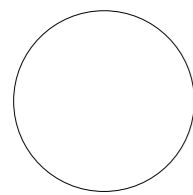

WHITE

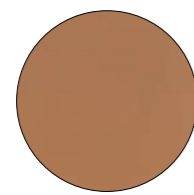

CAPPUCCINO

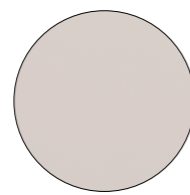

LIGHT GREY

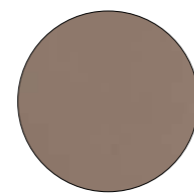

MUD



BRONZE

METAL FINISHES

Choose from 3 standard finishes or inquire about custom options.

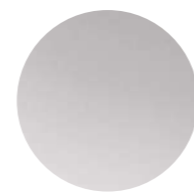

POLISHED CHROME



BRUSHED BRONZE



BRUSHED BRASS

MARBLE FINISHES

Choose from 5 standard finishes or inquire about custom options.



ARABESCATO WHITE

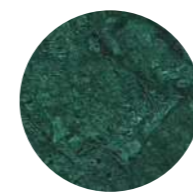

GREEN GUATEMALA

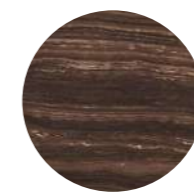

ERAMOSA BROWN



BLACK PORTORO



TRAVERTINO

PIGMENT
FRANCE

by GIOBAGNARA

UPDATE

FEBRUARY 2021 — SEPTEMBER 2020



GIORGIO BAGNARA, FOUNDER AND CEO OF GIOBAGNARA



Born into a family renowned for cultivating for three generations the art of living, Giorgio Bagnara became passionate about his calling at a very early age. In the late Nineties, after noticing that leather from the fashion industry was not considered enough as material for home accessories, he founded GIOBAGNARA with the goal of applying it to a complete collection. Along with his wife, Vanessa, he decided to move his design studios and workshops in the old docks of the Port of Genoa where, surrounded by the essence and beauty of that location, the company took a significant step forward.

PIGMENT FRANCE BY GIOBAGNARA

The respected luxury brand PIGMENT FRANCE, which joined the GIOBAGNARA group in January 2018, is a master at enhancing tableware and appliances with different materials such as straw, willow, rattan and, of course, several types of leather, bringing a new luxury to everyday objects.

The pieces presented in the collection pay homage to the creative variety and timeless poetry born from the meticulous craftsmanship of these elements.

Looking to the PIGMENT FRANCE workshop with its expert artisans, GIOBAGNARA aims to preserve and further develop the huge potential of this lifestyle manufacture. French manual skills and craftsmanship shine through in the beauty of its products, heritage and identity. GIOBAGNARA wants to introduce the brand to a more international audience that respects these values.

PIGMENT FRANCE creations live through time, as they represent the combination of industry and talent; the world is fascinated by the products from this land, by the care in the selection of raw materials as well as by the search for top-notch quality and creativity in each and every stage of the production chain.

As John Ruskin once wrote: "Quality is never an accident, it is always the result of high intention, sincere effort, intelligent direction and skillful execution; it represents the wise choice of many alternatives, the cumulative experience of many masters of craftsmanship."

**MATISSE
LEATHER & RATTAN
SIDE TABLE**

Metal structure available in different finishes boasting a top and a base made with woven leather and rattan.

Metal finishes available:
chrome / bronze / brass.

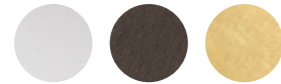

chrome bronze brass

small — PFA056
Ø cm 25 | h. cm 58

medium — PFA057
Ø cm 30 | h. cm 55

large — PFA058
Ø cm 35 | h. cm 52

Only available with natural rattan (RT06)
combined with golf or nappa leather.





DEAUVILLE
LEATHER & RATTAN
GLASS SUGAR BOWL WITH SPOON

Transparent borosilicate glass partially dressed
in woven leather and rattan.
It features a glass lid and spoon.



PFT210
Ø cm 9,5 | h. cm 10

Only available with natural rattan (RT06)
combined with golf or nappa leather.

DEAUVILLE
LEATHER & RATTAN
MILK JUG

Transparent borosilicate glass partially dressed
in in woven leather and rattan.



PFC045
Ø cm 7 | h. cm 9.5

Only available with natural rattan (RT06)
combined with golf or nappa leather.

**MARSEILLE
LEATHER & RATTAN
GLASS PITCHER**

Transparent borosilicate glass partially dressed in woven leather and rattan. Featuring a glass lid with silicone ring and heat-resistant glass body, it can be used for both hot and cold drinks.



0.75 LT — PFC047
cm 14 x 10 | h. cm 18.5

1.2 LT — PFC048
cm 14 x 10 | h. cm 24.5

Only available with natural rattan (RT06)
combined with golf or nappa leather.



WIDEVILLE
LEATHER & RATTAN
CANDLE HOLDER

Transparent borosilicate glass partially dressed in woven leather and rattan.



PFT212
Ø cm 9.5 | h. cm 10.5

Only available with natural rattan (RT06) combined with golf or nappa leather.

ANNECY
LEATHER & RATTAN
CUP

Transparent borosilicate glass partially dressed in woven leather and rattan.
The cover can be removed for an easy cleaning.



PFT211
Ø cm 9.5 | h. cm 10.5

Only available with natural rattan (RT06) combined with golf or nappa leather.

NEWS PRESENTED IN SEPTEMBER 2020



RENOIR
LEATHER & RATTAN
STOOL / SIDE TABLE

Wood structure covered in woven leather and rattan.



PFA021
Ø cm 36 | h. cm 43

Only available with natural rattan (RT06)
combined with golf or nappa leather.



MONET
LEATHER & RATTAN
STORAGE BASKET

Structure made in woven leather and rattan.



PFA226
Ø cm 31 | h. cm 34

Only available with natural rattan (RT06)
combined with golf or nappa leather.



CÉZANNE
LEATHER & RATTAN
BINS

Structure made in woven leather and rattan.
Metal container inside available in three finishes
of choice: polished chrome, brushed brass
and brushed bronze.



mini — PFA640
Ø cm 18.5 | h. cm 27.5

small — PFA650
Ø cm 24 | h. cm 30

medium — PFA660
Ø cm 30 | h. cm 34

umbrella stand — PFA042
Ø cm 29.5 | h. cm 49.5

Only available with natural rattan (RT06)
combined with golf or nappa leather.





NÎMES
LEATHER & RATTAN
BOWLS

Structure made in woven leather and rattan.



small — PFA011
Ø cm 19 | h. cm 9

medium — PFA012
Ø cm 19 | h. cm 11

large — PFA013
Ø cm 19 | h. cm 17

Only available with natural rattan (RT06)
combined with golf or nappa leather.

GIVERNY SQUARE TRAYS

Leather-bound wooden structure enriched
by a woven fine willow frame.



PFV305
cm 26 x 26 | h. cm 7



**ESSENZA
LEATHER & RATTAN
COFFEE MACHINE**

Original Nespresso machine
with a removable cover made
in woven leather and rattan.
It uses classic Nespresso capsules.

Voltage available: 110V or 220V.



PFN213
cm 10.5 x 33.5 | h. cm 21.5

removable cover — PFN213SC
cm 10.5 x 21 | h. cm 21.5

Only available with natural rattan (RT06)
combined with golf or nappa leather.

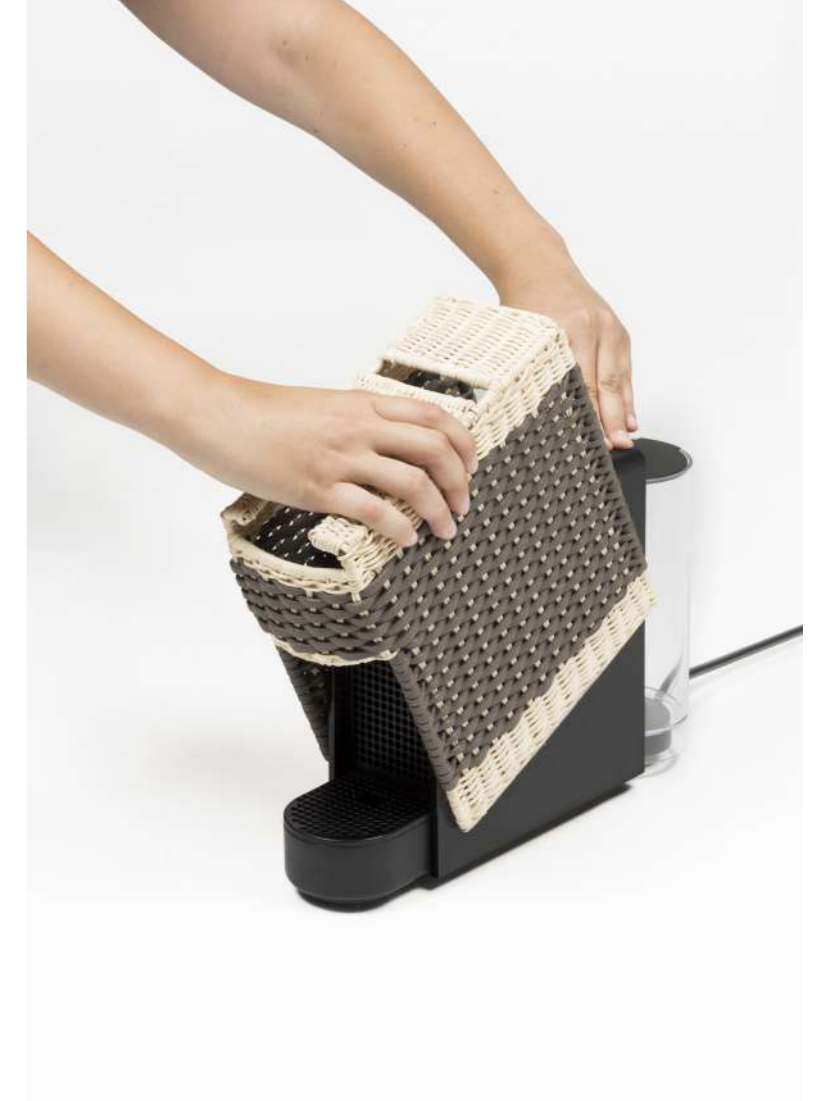
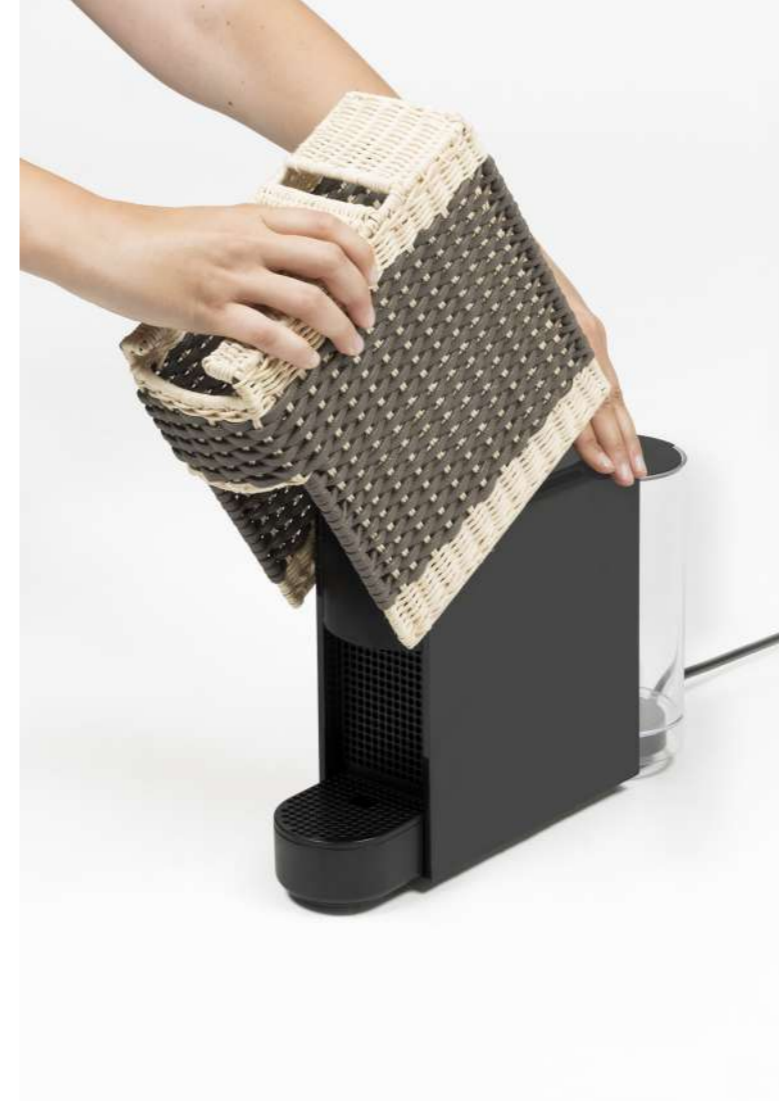



**MONCEAU
LEATHER & RATTAN
CARAFES**

Insulated stainless steel carafes with chrome-plated finish partially covered in woven leather and rattan. Two-chamber structure able to maintain liquid's temperatures. Precise pouring thanks to the specially developed hinged lid with one-hand operation.



0.6 LT — PFC241
cm 13.5 x 16 | h. cm 16.5

1.0 LT — PFC242
cm 14.5 x 17 | h. cm 20

1.5 LT — PFC243
cm 15 x 17.5 | h. cm 24

Only available with natural rattan (RT06)
combined with golf or nappa leather.





ARLES
LEATHER & RATTAN
CARAFE

Insulated stainless steel carafes partially covered in woven leather and rattan with chrome-plated finish. Two-chamber glass structure able to maintain the liquid's warm temperatures for up to 12 hours and cold temperatures for up to 24 hours. Precise pouring thanks to the specially developed lid with one-hand operation.



1.0 LT — PFC205
cm 15 x 18 | h. cm 26

Only available with natural rattan (RT06)
combined with golf or nappa leather.

RENNES
LEATHER & RATTAN
CARAFES

Insulated stainless steel carafes with chrome-plated finish and partially covered in woven leather and rattan.
Two-chamber structure able to maintain the liquid's temperatures.



0.3 LT — PFC375
cm 8.5 x 12 | h. cm 16

0.6 LT — PFC376
cm 9 x 13.5 | h. cm 20

1.2 LT — PFC377
cm 11 x 15.5 | h. cm 24

Only available with natural rattan (RT06)
combined with golf or nappa leather.



MENTON
LEATHER & RATTAN
BOTTLE COOLER /
ICE BUCKETS

Two-chamber insulated stainless steel structure covered in rattan.
Items able to keep bottles cool for several hours.



bottle cooler — PFC232
Ø cm 14 | h. cm 21.5

small ice bucket — PFC221
Ø cm 17.5 | h. cm 19

large ice bucket — PFC222
Ø cm 21 | h. cm 22

Only available with natural rattan (RT06)
combined with golf or nappa leather.

GUIMET
LEATHER & RATTAN
BOTTLE COOLER

Finest regenerated leather structure covered in woven leather and rattan.
Non-slip waterproof rubber base underneath.
Removable stainless steel inner container for easy cleaning.
Works with 4 reusable ice packs, included.



PFC230
Ø cm 16 | h. cm 20

Only available with natural rattan (RT06)
combined with golf or nappa leather.



**MENTON
LEATHER & RATTAN
CHAMPAGNE BUCKETS
N°2**

Two-chamber insulated stainless steel structure covered in woven leather and rattan. This article's cooling action lasts for several hours.

**MENTON
LEATHER & RATTAN
CHAMPAGNE BUCKET STANDS**

Stainless steel structure with a heavy solid base and central column covered in woven leather and rattan.

Perfect in combination with our Menton leather & rattan champagne buckets, but also able to host any other model with a maximum lower diameter of 20 cm.

champagne bucket
one bottle — PFC591
Ø cm 25 | h. cm 25.5

champagne bucket
two - three bottles — PFC592
Ø cm 29.5 | h. cm 24

champagne bucket
four - five bottles — PFC593
Ø cm 39 | h. cm 25.5

small stand — PFC595
Ø cm 25 | h. cm 62
Compatible with:
PFC591 and PFC592

large stand — PFC596
Ø cm 37.5 | h. cm 63
Compatible with:
PFC593

champagne bucket + stand
one bottle — PFC597
Ø cm 25 | h. cm 82.5

champagne bucket + stand
two - three bottles — PFC598
Ø cm 29.5 | h. cm 85

champagne bucket + stand
four - five bottles — PFC599
Ø cm 39 | h. cm 86.5

Only available with natural rattan (RT06) combined with golf or nappa leather.



**DIJON
LEATHER & RATTAN
CARAFE**

Fine crystal carafe partially covered in woven leather and rattan.
Available with a stainless steel swing top lid with built-in icestopper and silicone seal.
Capacity: 1 LT



PFC172
Ø cm 11.5 | h. cm 30

with pourer — PFC174
Ø cm 11.5 | h. cm 34.5

Only available with natural rattan (RT06)
combined with golf or nappa leather.



WIDEVILLE
LEATHER & RATTAN
CANDLE HOLDERS /
VASE

Candle holders made of transparent borosilicate glass and partially covered in woven leather and rattan.
Can be used as vases.



small — PFC109
Ø cm 13 | h. cm 20

large — PFC112
Ø cm 16 | h. cm 22

Only available with natural rattan (RT06)
combined with golf or nappa leather.



TOLEDO
LEATHER & RATTAN
ASHTRAY

Chrome plated brass structure partially dressed
in woven leather and rattan.

Featuring an easy-to-clean ash basin, this windproof
ashtray keeps spaces tidy by enclosing cigarette
butts and ashes in a sealed chamber which can be
emptied when needed.



PFS768

cm 12.5 x 11 | h. cm 7

Only available with natural rattan (RT06)
combined with golf or nappa leather.



ROUEN
LEATHER & RATTAN
MANUAL LOTION DISPENSER

Dressed with meticulously **woven rattan** and **leather**, this lotion dispenser with a **capacity of 500ml** is ideal for hotels, yachts, offices, shops, private residences and interiors in general.

It helps maintaining a clean environment and offers easy access to lotion, soap or hand sanitizer.

It features a **glass bottle**, provided with a **spout available in three metal finishes** of choice: polished chrome, brushed brass and brushed bronze.



PFB092
cm 8.5 x 11 | h. cm 23

refill — HA113RE
500ml

Only available with natural rattan (RT06)
combined with golf or nappa leather.



CALAIS
LEATHER & RATTAN
SOAP DISPENSER /
TOOTHBRUSH HOLDER

Dressed with meticulously **woven rattan** and **leather**, this lotion dispenser with a **capacity of 500ml** is ideal for hotels, yachts, offices, shops, private residences and interiors in general.

It helps maintaining a clean environment and offers easy access to lotion, soap or hand sanitizer.

It features a **glass bottle**, provided with a **spout available in three metal finishes** of choice: polished chrome, brushed brass and brushed bronze.



soap dispenser — PFB097
Ø cm 8.5 | h. cm 19.5

toothbrush holder — PFB098
Ø cm 8.5 | h. cm 13.5

Only available with natural rattan (RT06)
combined with golf or nappa leather.



ANTIBES
LEATHER & RATTAN
TISSUE HOLDER

Fine woven leather and rattan structure.



rectangular — PFB105
cm 25.5 x 14 | h. cm 8

square — PFB106
cm 14 x 14 | h. cm 13.5

Only available with natural rattan (RT06)
combined with golf or nappa leather.





FINISHES

G — PRINTED CALFSKIN GOLF
price category: A

PIGMENT FRANCE calf leather comes from northern Europe. It is tanned in Italy with a special treatment that makes it waterproof and scratch-resistant. The creations made by our artisans in northern France stand apart thanks to their perfect construction and impeccable craftsmanship. Our talented team applies its skills to these precious leathers and it is in the hands of these artisans that the real magic happens: the challenge of covering curved surfaces and taking everyday objects to a new level of luxury and sophistication.

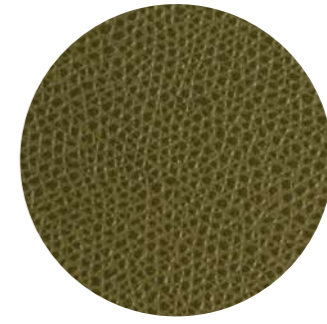

G98
olive green

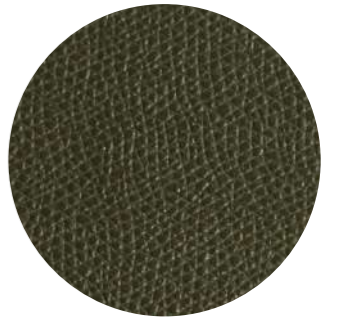

G02
loden green

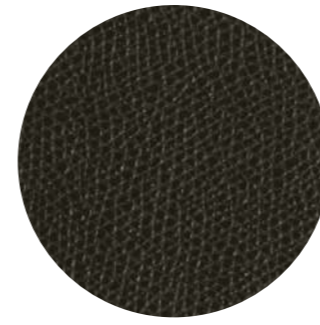

G57
cipress

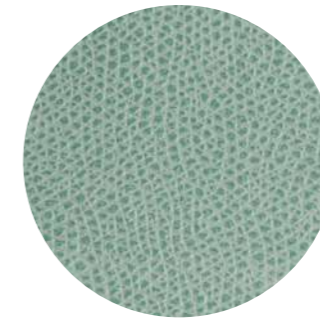

G46
mint

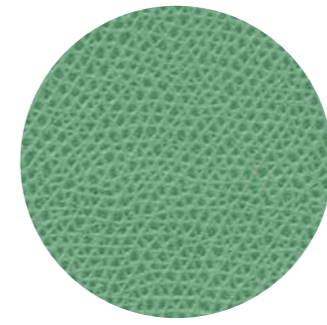

G43
pistachio

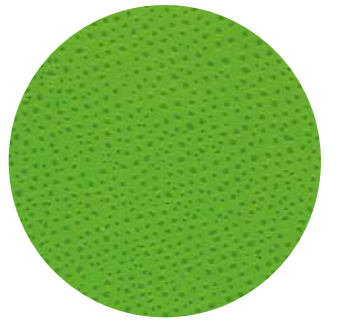

G26
apple green

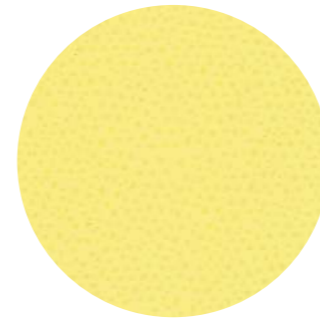

G27
lemon

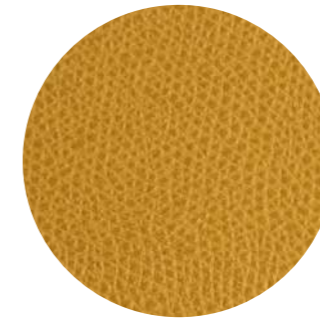

G76
mustard

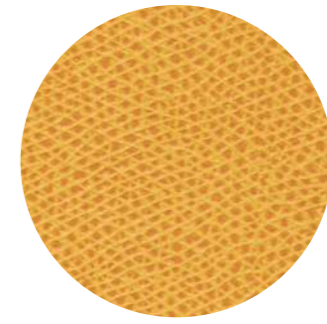

G03
yellow

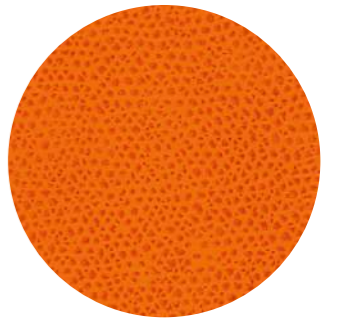

G04
orange



G38
mango



G05
white



G95
off white

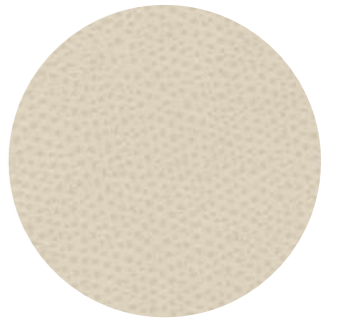

G06
ivory

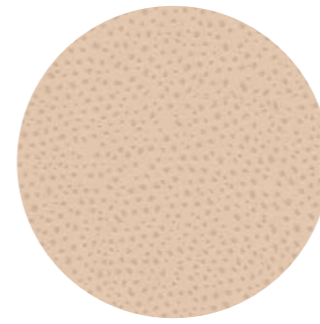

G28
cipria

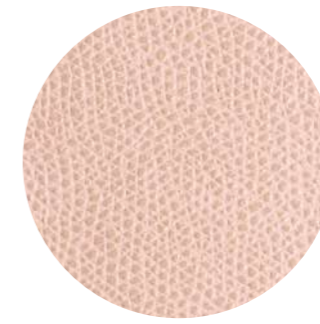

G91
nude

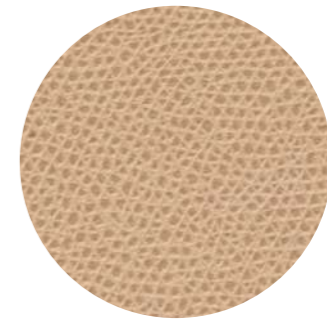

G42
cappuccino

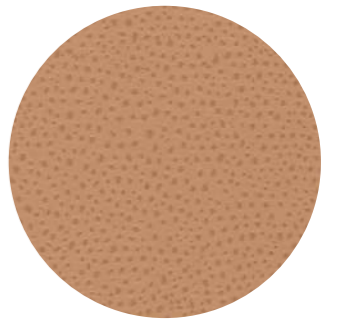

G07
sand

G — PRINTED CALFSKIN GOLF
price category: A

PIGMENT FRANCE calf leather comes from northern Europe. It is tanned in Italy with a special treatment that makes it waterproof and scratch-resistant. The creations made by our artisans in northern France stand apart thanks to their perfect construction and impeccable craftsmanship. Our talented team applies its skills to these precious leathers and it is in the hands of these artisans that the real magic happens: the challenge of covering curved surfaces and taking everyday objects to a new level of luxury and sophistication.

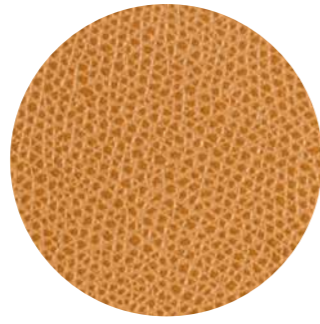

G51
caramel

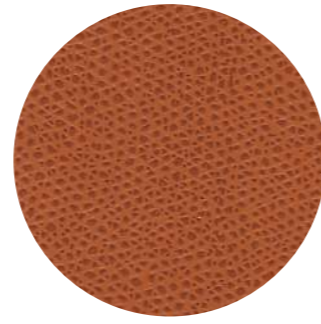

G08
siena

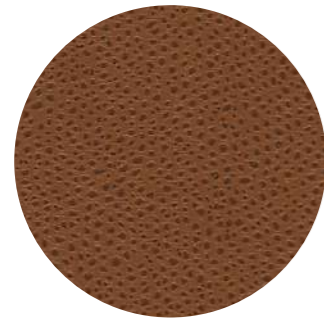

G30
tobacco

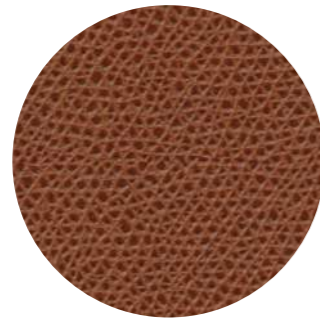

G82
rust

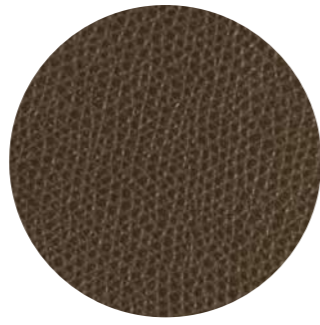

G96
clay

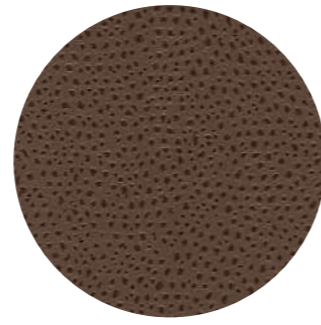

G09
brown



G25
moka

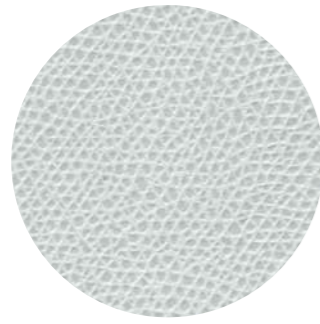

G49
ice

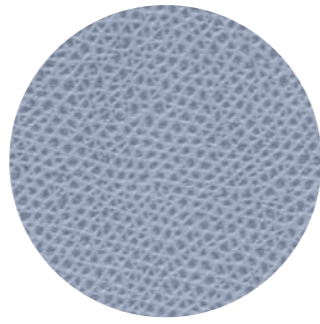

G29
lilac gray

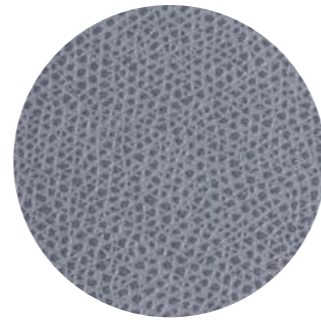

G41
storm grey

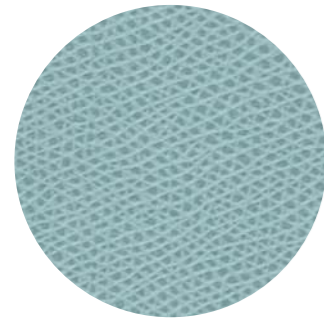

G66
sky

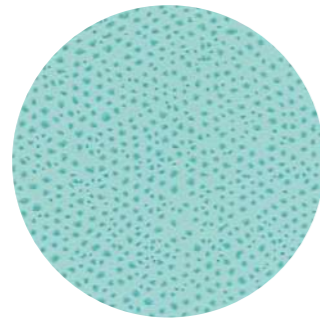

G10
light blue

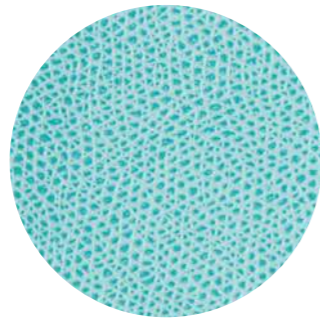

G60
capri

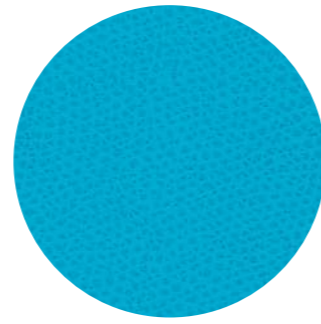

G22
turquoise

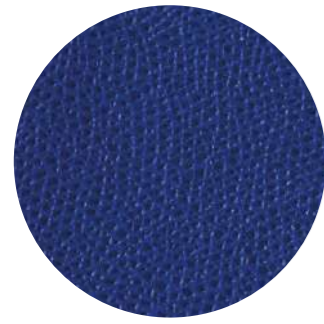

G32
ultramarine

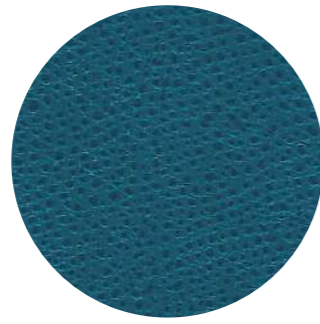

G31
petrol blue

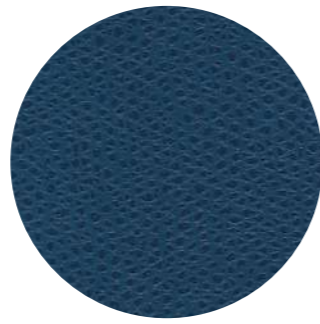

G12
royal blue

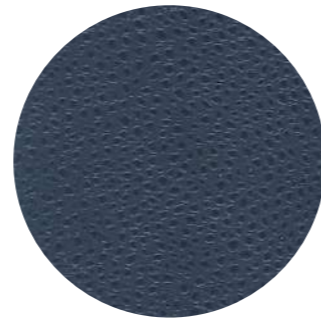

G33
ocean

G — PRINTED CALFSKIN GOLF
price category: A

PIGMENT FRANCE calf leather comes from northern Europe. It is tanned in Italy with a special treatment that makes it waterproof and scratch-resistant. The creations made by our artisans in northern France stand apart thanks to their perfect construction and impeccable craftsmanship. Our talented team applies its skills to these precious leathers and it is in the hands of these artisans that the real magic happens: the challenge of covering curved surfaces and taking everyday objects to a new level of luxury and sophistication.

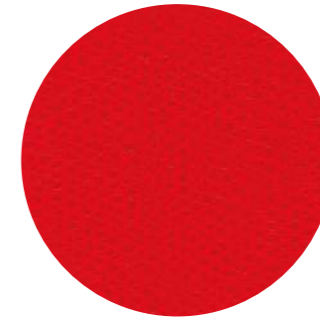

G23
coral

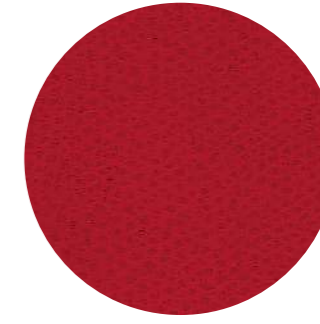

G13
red

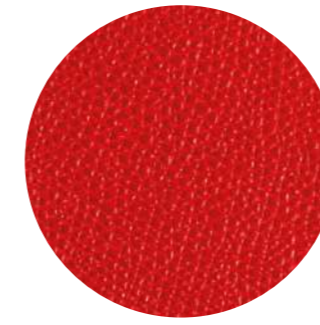

G48
scarlet

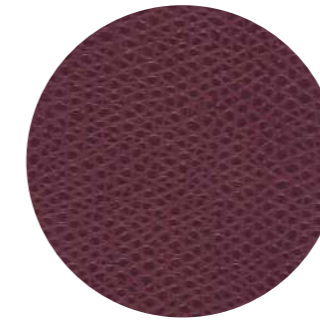

G17
bordeaux



G93
plum

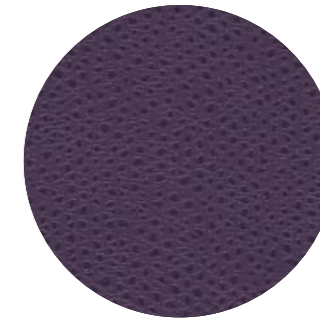

G16
violet

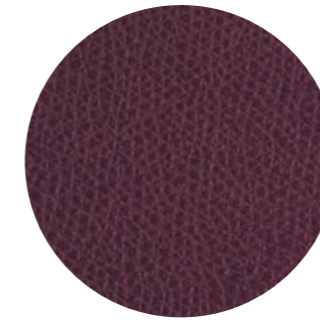

G36
grape

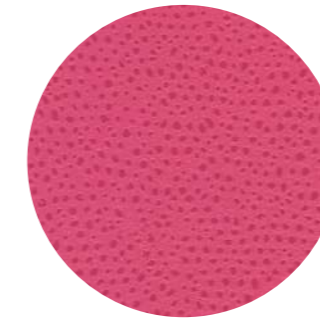

G35
raspberry

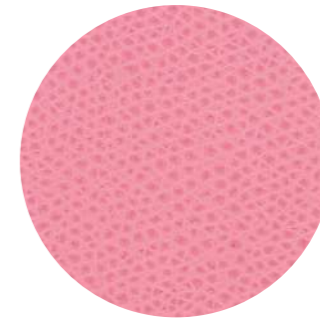

G34
pink

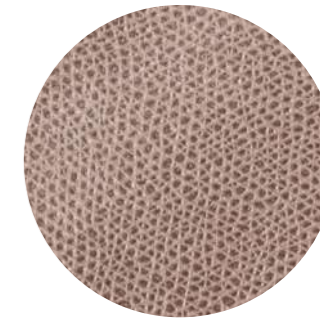

G45
dove

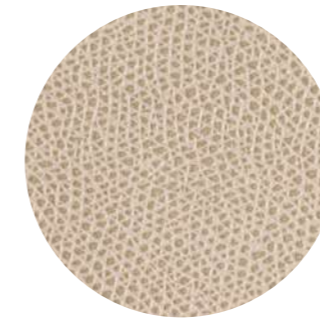

G83
stone

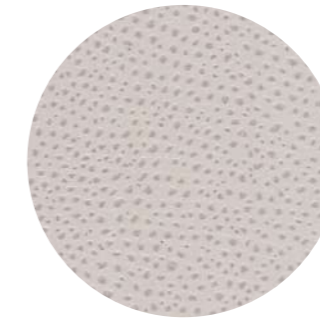

G37
light grey

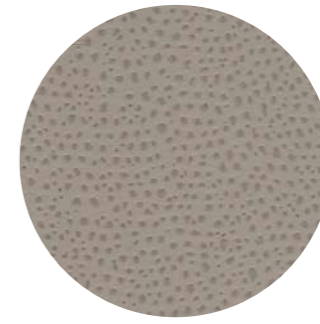

G18
grey

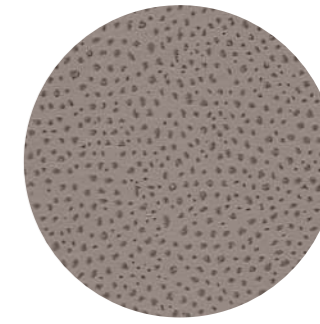

G21
mud

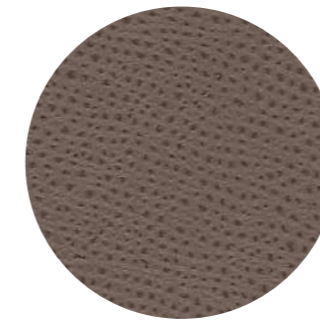

G24
smoke

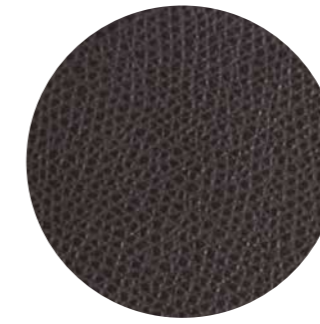

G67
lava

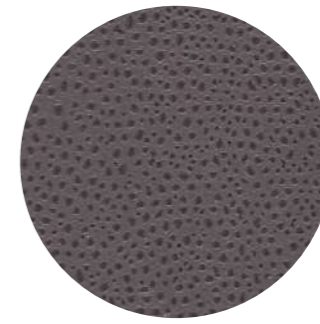

G19
graphite

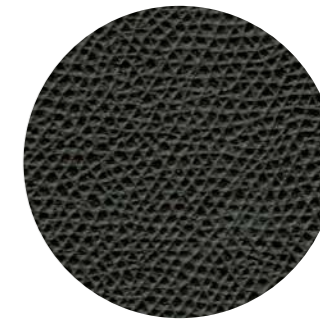

G77
slate

G — PRINTED CALFSKIN GOLF
price category: A

PIGMENT FRANCE calf leather comes from northern Europe. It is tanned in Italy with a special treatment that makes it waterproof and scratch-resistant. The creations made by our artisans in northern France stand apart thanks to their perfect construction and impeccable craftsmanship. Our talented team applies its skills to these precious leathers and it is in the hands of these artisans that the real magic happens: the challenge of covering curved surfaces and taking everyday objects to a new level of luxury and sophistication.



G20
black



G61
pearl



G63
moonsand



G54
copper



G56
bronze



G58
titanium



G52
silver



G50
gold

F — CALFSKIN NAPPA
price category: A

PIGMENT FRANCE calf leather comes from northern Europe. It is tanned in Italy with a special treatment that makes it waterproof and scratch-resistant. The creations made by our artisans in northern France stand apart thanks to their perfect construction and impeccable craftsmanship. Our talented team applies its skills to these precious leathers and it is in the hands of these artisans that the real magic happens: the challenge of covering curved surfaces and taking everyday objects to a new level of luxury and sophistication.

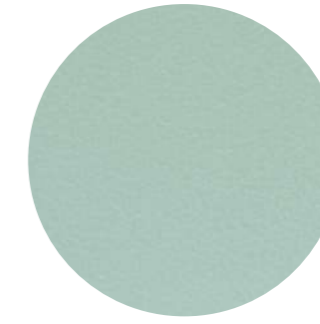

F46
mint

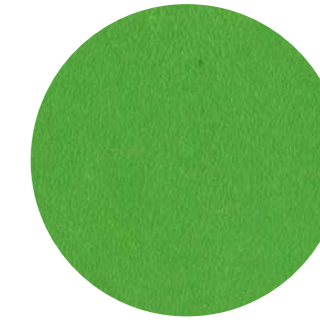

F26
apple green



F02
loden green



F76
mustard

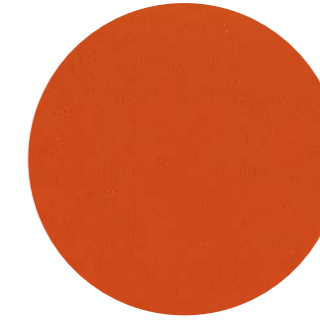

F04
orange

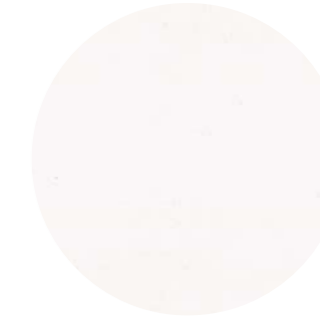

F05
white



F95
off white

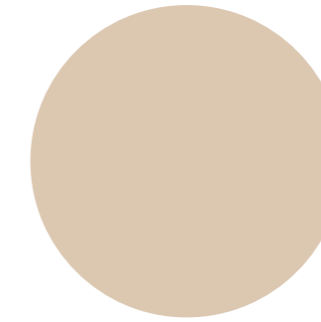

F06
ivory

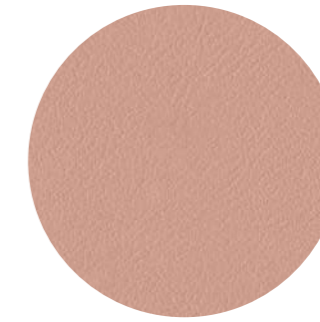

F91
nude



F42
cappuccino

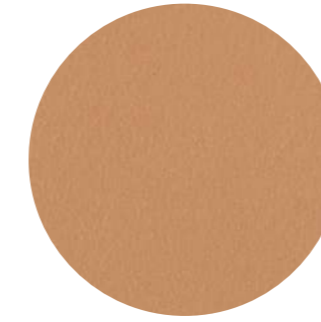

F51
caramel

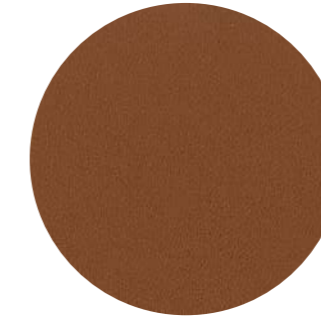

F08
siena

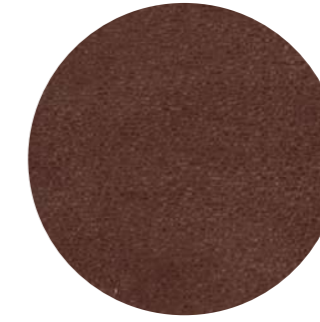

F82
rust



F09
brown



F10
light blue

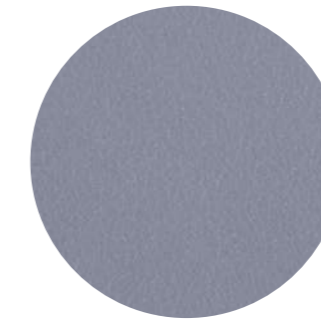

F41
storm grey

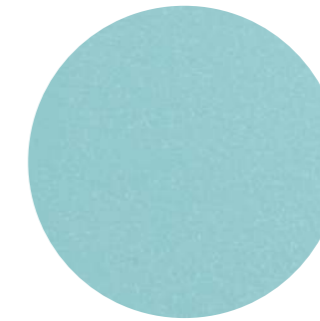

F60
capri

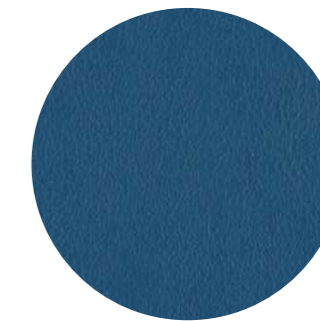

F68
denim

F — CALFSKIN NAPPA

price category: A

PIGMENT FRANCE calf leather comes from northern Europe. It is tanned in Italy with a special treatment that makes it waterproof and scratch-resistant.

The creations made by our artisans in northern France stand apart thanks to their perfect construction and impeccable craftsmanship.

Our talented team applies its skills to these precious leathers and it is in the hands of these artisans that the real magic happens: the challenge of covering curved surfaces and taking everyday objects to a new level of luxury and sophistication.



F31
petrol blue

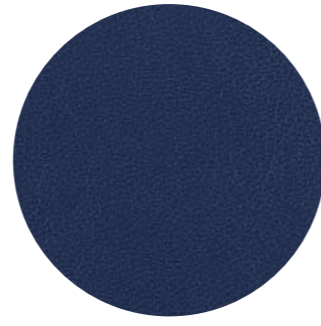

F12
royal blue



F33
ocean

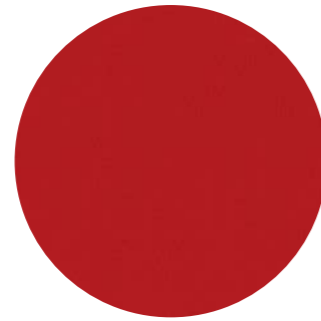

F13
red



F53
pink peony



F79
wine



F17
bordeaux



F65
antique rose



F93
plum



F83
stone

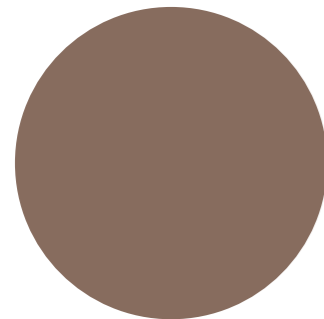

F21
mud



F24
smoke



F96
clay



F71
rock



F19
graphite

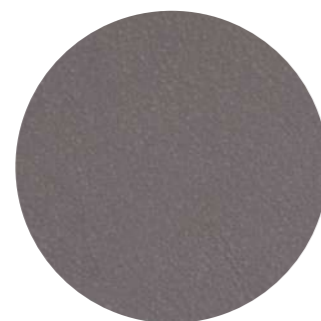

F67
lava



F77
slate



F20
black

RT — RATTAN

price category: E

Rattan is a close relative of the palm tree. It is a type of a vine that grows quickly in the jungles of Southeast Asia. It has the shape of a pole, and its diameter varies between one and three inches. It is one of the strongest woods, highly durable and hard to break. The solid core of rattan, along with its vertical grains, is harvested and cut into smaller sections before being steamed and molded into various shapes. PIGMENT FRANCE's rattan is completely hand-dyed and hand-woven by our artisans in northern France.



RT06
natural



RT42
light brown



RT47
dark brown



RT20
black

WF — FINE WILLOW

price category: F

PIGMENT FRANCE creations in fine willow stand out because of the smaller rods selected to create an extremely fine pattern. The structure is made of rigid willow sticks (the 'stake' material), around which thinner flexible rods are woven (the 'strand' material). By using only Osier (Salix Viminalis), perhaps the most valued of the wild willows, that is locally sourced, we pride ourselves on making a quality, eco-friendly product.

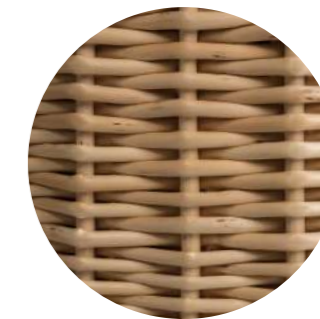

WF06
natural

WW — WILLOW

price category: G

Some of mankind's earliest tools may have been made from willow. In PIGMENT FRANCE's creations, willow wicker is used almost as a textile by our artisans in northern France. The structure is made of rigid willow sticks (the 'stake' material), around which thinner flexible rods are woven (the 'strand' material). By using only Osier (Salix Viminalis), perhaps the most valued of the wild willows, that is locally sourced, we pride ourselves on making a quality, eco-friendly product.



WW06
natural

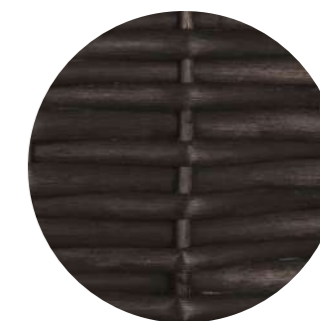

WW20
black

TS — TECHSTRAW
price category: H

TechStraw is a polyamide braided material sewn by our artisans in northern France. Available in many colors, it is lightweight, extremely durable, water-resistant and washable.



TS03
yellow



TS04
orange



TS05
white



TS06
ivory



TS28
cipria



TS30
tobacco



TS25
moka



TS22
turquoise



TS11
cobalt blue



TS12
royal blue



TS23
coral



TS34
pink



TS15
wisteria



TS37
light grey



TS18
grey



TS21
mud



TS20
black

STEPHANEPARMENTIER
×
GIOBAGNARA

UPDATE
FEBRUARY 2021 — SEPTEMBER 2020

GIOBAGNARA AND STÉPHANE PARMENTIER

Stéphane Parmentier first met Giorgio Bagnara a few years ago in the aisles of a professional trade show. Enamored of the beauty and the quality of the leathers used, not to mention the meticulous attention to detail evident in each piece, he regularly contacted GIOBAGNARA to realize the custom-made home furnishings in leather or suede that he designed for private clients.

Very soon, the two built a rapport based on a shared sense of rigor, a quest for excellence down to the smallest detail and a taste for modern elegance expressed through sleek design, beautiful materials — and a mutual taste for audacity.

In 2017, their animated creative dialogue and a shared ambition to bring a new perspective to the market naturally led Giorgio Bagnara to entrust Stéphane Parmentier with the artistic direction of GIOBAGNARA. Since the beginning of this collaboration, Stéphane Parmentier has designed a wide number of new creations for the brand, from boxes, cases, desktop objects, storage units, change trays, trays, candle holders and vases to furniture and leather — or suede — trimmed lamps in a wide array of colours.

In blending tradition, aesthetic heritage and modernity, Stéphane Parmentier brings a graphic and sensual sensibility to a typically Italian art of living of which he is particularly fond.



**GIORGIO BAGNARA,
FOUNDER AND CEO
OF GIOBAGNARA**

Born into a family renowned for cultivating for three generations the art of living, Giorgio Bagnara became passionate about his calling at a very early age. In the late Nineties, after noticing that leather from the fashion industry was not considered enough as material for home accessories, he founded GIOBAGNARA with the goal of applying it to a complete collection. Along with his wife, Vanessa, he decided to move his design studios and workshops in the old docks of the Port of Genoa where, surrounded by the essence and beauty of that location, the company took a significant step forward.

GIOBAGNARA

A brand that is distinctive for elegantly designed creations that express luxury without ostentation, available in an uncommon and virtually limitless colour palette of leathers and suede, and crafted to the highest standards using both traditional know-how and leading-edge technology. This approach to tradition and modernity led Giorgio Bagnara to experiment: he constantly pushes technical limits in his quest for objects that are both beautiful and relevant, and in doing so relies on the skills of the company's craftspeople. Very quickly, GIOBAGNARA became renowned for its expertise, and its founder became a partner of choice for a large number of interior decorators and yacht and jet designers who called upon his know-how for special commissions. In 2015, Giorgio Bagnara expanded its leather portfolio with the acquisition of the saddle leather specialist Rabitti 1969. Today, nearly two decades after its founding, GIOBAGNARA has one of the most comprehensive offers of leather home accessories on the market and is preparing to open a fresh chapter in its history.



**STÉPHANE PARMENTIER
CREATIVE DIRECTOR
OF GIOBAGNARA**

The interior architect and designer Stéphane Parmentier began his career working for Karl Lagerfeld before deciding to devote himself to architecture full-time in 2002. Since then, he has created and developed numerous projects for an international clientele attuned to his style of luxurious simplicity. The homes and objects he designs reveal a vision that is deeply anchored in a modern everyday lifestyle. Inspired by classical Greco-Roman antiquity, the beauty of the Puglian landscape, the restraint of the Japanese aesthetic, and a desire to focus on the essential, he cultivates elegant asceticism by associating noble materials with subtly graphic lines.

LIPARI TABLE LAMPS

Lipari is a collection that aims to find harmony between opposites: the natural, delicate texture of the woven rattan shade on each lamp reveals a beautiful, soothing glow when lit, while the geometrical rigor of the sturdy metal base creates captivating strong contrasts, boasting an exceptional magnetic charm.

Metal finishes available:
chrome / bronze / brass.



chrome bronze brass

small — LTP021
cm 31.5 x 20 | h. cm 36
light bulb E27 100 W

medium — LTP022
cm 43 x 29 | h. cm 50
light bulb E27 100 W

large — LTP023
cm 51.5 x 35 | h. cm 60
light bulb E27 100 W

base: aluminium
lampshade: woven rattan







NEWS PRESENTED IN SEPTEMBER 2020

TABOU
MARBLE
SCULPTURES

The Tabou collection's statement pieces are now declined in their all-travertine version, featuring a selection of elegant nuances.

A mix of space-age design and tribal art, these contemporary totems are great decorative pieces able to create a connection between abstraction and figuration.



TABOU
MARBLE
SCULPTURE
1



HAP081M
cm 21.5 x 15.5 | h. cm 55

marble: 5 varieties of travertine
metal: bronze

TABOU
MARBLE
SCULPTURE
2



HAP082M
cm 27.5 x 15 | h. cm 51.5

marble: 4 varieties of travertine
metal: bronze

TABOU
MARBLE
SCULPTURE
5



HAP085M
cm 72 x 18 | h. cm 54

marble: 6 varieties of travertine
metal: bronze

EOLIE TABLE LAMPS

Eolie is a collection where the meticulous perfection of handmade weaving meets the flawless, elegant simplicity of pure forms and proportions.

The woven rattan, with its warm natural nuances, boasts captivating light and dark effects and conveys a feeling of weightlessness, while the combination with an ideally heavy metal base brings forth a subtle interplay of contrasting yet complimentary textures.

round — LFP013
Ø cm 27 | h. cm 41

square — LFP014
cm 25 x 25 | h. cm 41

material: woven rattan
metal: bronze







GLENN SESTIG
×
GIOBAGNARA

UPDATE

FEBRUARY 2021 — SEPTEMBER 2020



GIORGIO BAGNARA, FOUNDER AND CEO OF GIOBAGNARA

Born into a family renowned for cultivating for three generations the art of living, Giorgio Bagnara became passionate about his calling at a very early age. In the late Nineties, after noticing that leather from the fashion industry was not considered enough as material for home accessories, he founded GIOBAGNARA with the goal of applying it to a complete collection. Along with his wife, Vanessa, he decided to move his design studios and workshops in the old docks of the Port of Genoa where, surrounded by the essence and beauty of that location, the company took a significant step forward.

GIOBAGNARA

A brand that is distinctive for elegantly designed creations that express luxury without ostentation, available in an uncommon and virtually limitless color palette of leathers and suede, and crafted to the highest standards using both traditional know-how and leading-edge technology. This approach to tradition and modernity led Giorgio Bagnara to experiment: he constantly pushes technical limits in his quest for objects that are both beautiful and relevant, and in doing so relies on the skills of the company's craftspeople. Very quickly, GIOBAGNARA became renowned for its expertise, and its founder became a partner of choice for a large number of interior decorators and yacht and jet designers who called upon his know-how for special commissions. In 2015, Giorgio Bagnara expanded its leather portfolio with the acquisition of the saddle leather specialist Rabitti 1969. Today, nearly two decades after its founding, GIOBAGNARA has one of the most comprehensive offers of leather home accessories on the market and is preparing to open a fresh chapter in its history.



GLENN SESTIG

Glenn Sestig, born in 1968 in Ghent, Belgium, graduated from the Henri Van De Velde institute in Antwerp and in 1999 established a practice together with painter Bvardk. From the outset, their work focused on extreme precision, on a construction with such mastery of the architectural line, proportions and perspective that it is easy to forget the careful consideration that will have gone into their design and creation.

In addition to the material and its interpretation, transparency and the play of reflection suggest, rather than illustrate, the endeavors that have resulted in the real grandeur of some projects, primarily places for public use. Glenn Sestig Architects is synonymous with contemporary chic. His work can be seen as unrelentingly urban and contemporary - materials are exclusive and its combinations are renewing and unique.

To give his work coherence, the architect uses his own method of calculation, a sort of mental model from which flow the intelligence, equilibrium and soul of a place. Each completed work is considered as a minor work of art wherein art and fashion are essential sources of inspiration. The architecture is no longer a movement in time but becomes a declaration of a global luxurious lifestyle. With regular publications in renowned magazines and recognition in global architectural awards, Glenn Sestig has earned his place as one of the most noticeable architects out there. Early commissions included shops, nightclubs and penthouses in Ghent, Antwerp and Brussels, but over the last couple of years the projects grew in size ranging from villas to hotels. Thanks to some magnificent projects with great exposure Glenn Sestig received international recognition with projects from Los Angeles to Tokyo.



LLOYD COLLECTION

The cultural exchange between Flanders and the Republic of Genoa dates back to the 15th century when there were close ties between traders and bankers in the two countries. Flemish paintings and tapestries were avidly collected by the Genoese banking families.

At the beginning of the 17th century, Genoa rapidly became the financial centre of Europe and its patricians acted as a magnet for artists.

Peter Paul Rubens and Anthony van Dyck both visited the trading centre and immortalised its aristocracy in sumptuous portraits, influencing generations of artists. Moreover, Rubens copied the magnificent architecture of the Genoese palazzi in drawings he later published in book form.

In the furrow traced centuries ago, GIOBAGNARA commissioned Glenn Sestig architect to design a new range of products in which the craftsmen of Ligurian Coast and a Flemish Master meet again.

This is how Lloyd Collection was born.

The Belgian architect imagined this design as a blending of East and West, and therefore, it doesn't fit neatly into either lineage. As with all of his architecture, Sestig sees in this project the possibility of an interaction between elegance and substance. The resulting design is a decorative, hybrid creation where the succession of solid and void spaces breaks the monolithic vision.

Lloyd is a collection where natural elements such as dark-stained Canaletto walnut wood, travertine, cashmere and wool play a calm symphony of craftsmanship, serenity and aesthetics.

LLOYD
MARBLE
RECTANGULAR TRAYS
+ FRAME

Travertine structure with brushed
burnished bronze frame.
Custom sizes available on request.

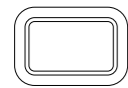
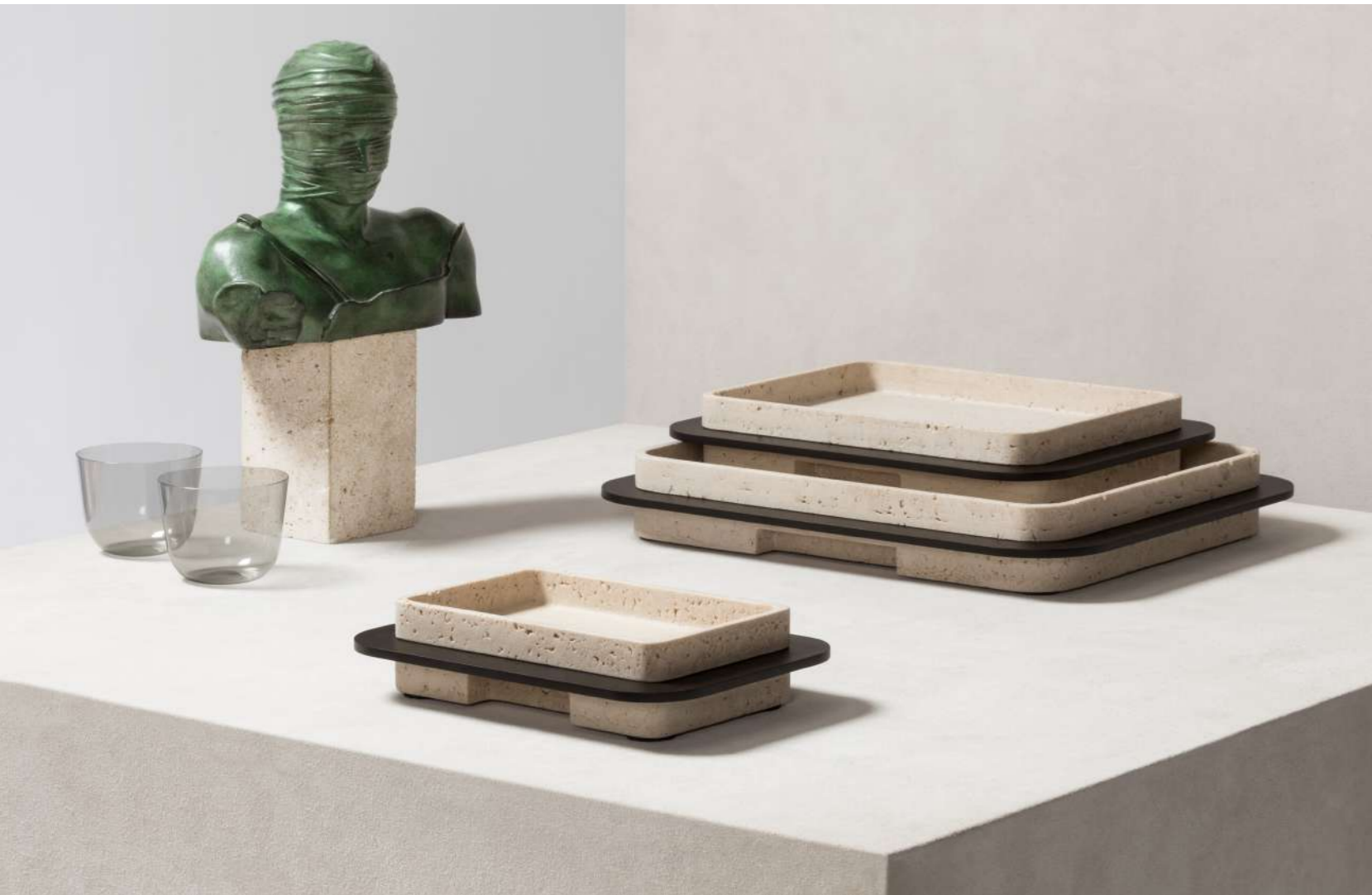

rectangular n°1
GSTV550M
cm 26 x 18 | h. cm 6

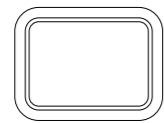

rectangular n°2
GSTV551M
cm 34 x 26 | h. cm 6

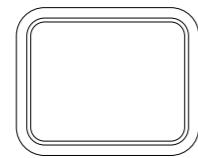

rectangular n°3
GSTV552M
cm 42 x 34 | h. cm 6



LLOYD BOOKSTAND

Materials: leather and wood
(the wood finish can be either
dark-stained Canaletto walnut
or wenge), leather and travertine
or all-travertine.
Custom sizes available on request.

Wood finishes available:
dark walnut / ziricote.



dark
walnut

wenge

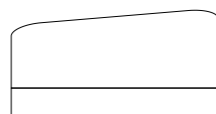

leather & wood
GSHA011
cm 36 x 24 | h. cm 12.5

leather & marble
GSHA012
cm 36 x 24 | h. cm 12.5

all-marble
GSHA011M
cm 36 x 24 | h. cm 12.5



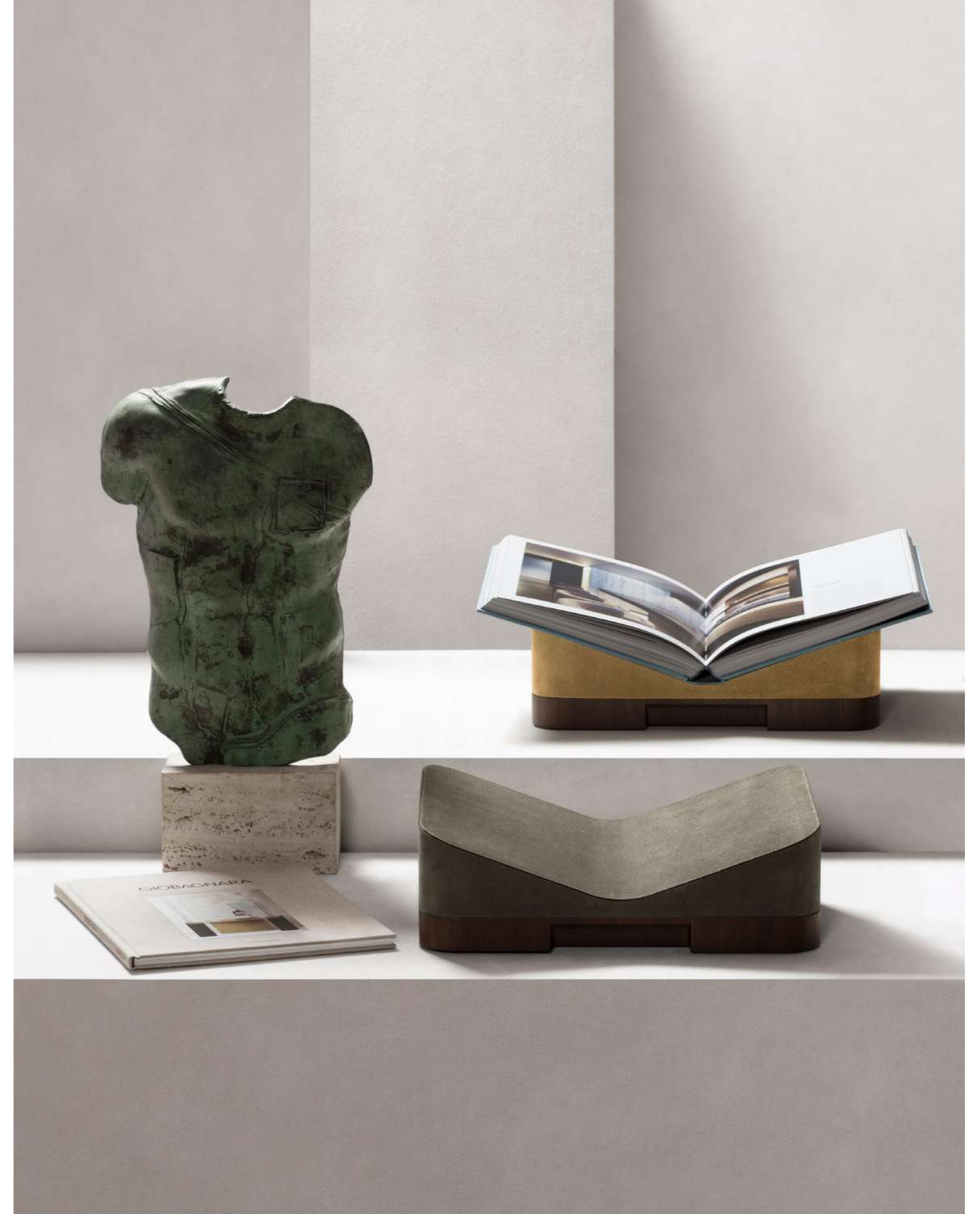



LLOYD FIREPLACE SET

Materials: leather and iron
with burnished bronze finish.
Custom sizes available on request.

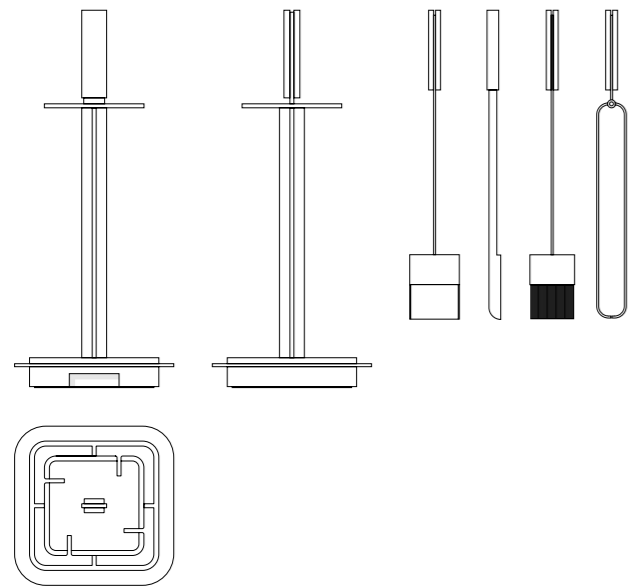

GSHA014
cm 36 x 36 | h. cm 76



LLOYD
POUFS & ARMCHAIR
SHEARLING VERSION

Materials: top in shearling,
base in dark-stained Canaletto walnut wood.
Custom sizes available on request.

low pouf
GSHS431
cm 40 x 40 | h. cm 32

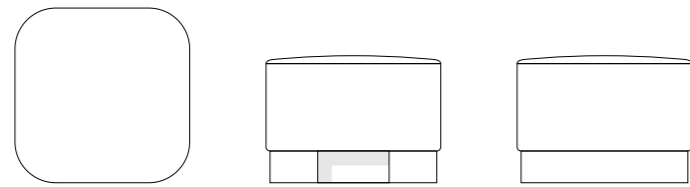

high pouf
GSHS433
cm 40 x 40 | h. cm 43

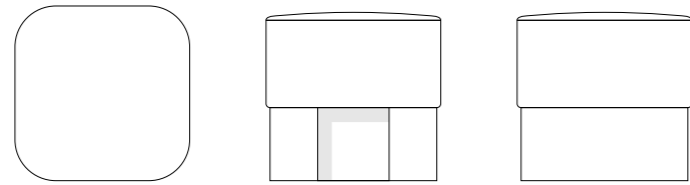

armchair
GSHS435
cm 61 x 52 | h. cm 55
seat height: cm 42

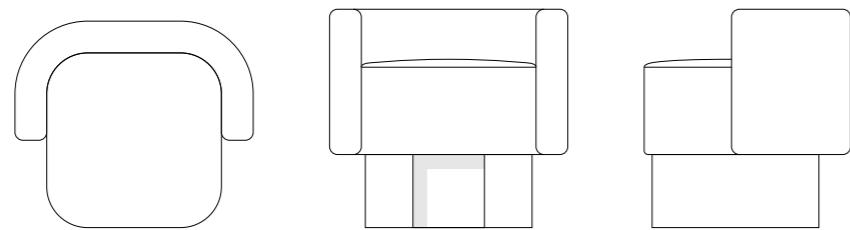



LLOYD
CHAIR

Materials: top in cashmere and wool or shearling,
base in dark-stained Canaletto walnut wood.
It features stainless steel feet.
Custom sizes and fabric available on request.



Example of Lloyd custom-made chair with Raf Simons fabric

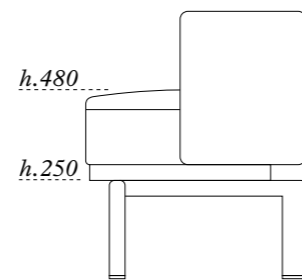
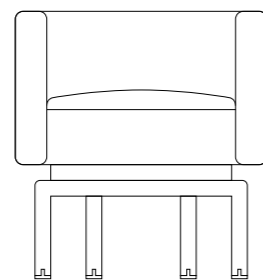
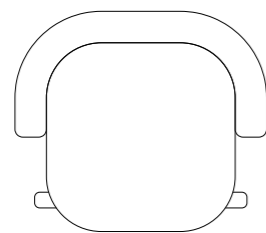

GSHS438
cm 64 x 56 | h. cm 68
seat height: cm 48
legs height: cm 25

LLOYD LOW CHAIR

Materials: top in cashmere and wool or shearling,
base in dark-stained Canaletto walnut wood.
It features stainless steel feet.
Custom sizes and fabric available on request.



Example of Lloyd custom-made low chair with Raf Simons fabric

GSHS439
cm 64 x 56 | h. cm 58
seat height: cm 42
legs height: cm 15

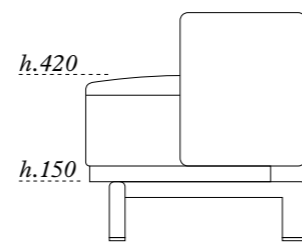
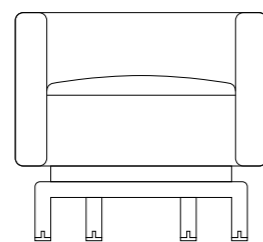
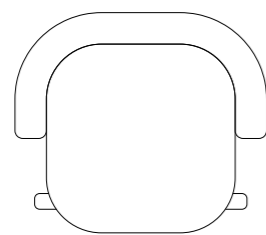

Example of Lloyd custom-made low chair with Raf Simons fabric



LLOYD SIDE TABLES + REMOVABLE TRAY

Materials: leather and wood.
The wood finish can be either dark-stained Canaletto walnut or Ziricote, a precious exotic wood (origin: Central America) characterized by an irregular dark veining that almost looks like a decorative motif. Provided with removable tray. Custom sizes available on request.

Wood finishes available:
dark walnut / ziricote.



dark walnut ziricote

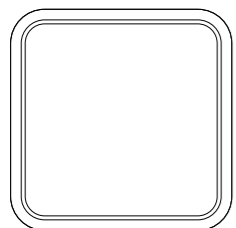

square high
walnut — GSMT001
cm 50 x 50 | h. cm 53.5
Lloyd square tray
+ frame n°5 on top
(code GSTV544)

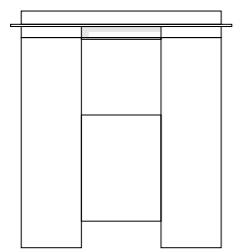

square high
ziricote — GSMT006
cm 50 x 50 | h. cm 53.5
Lloyd square tray
+ frame n°5 on top
(code GSTV544)

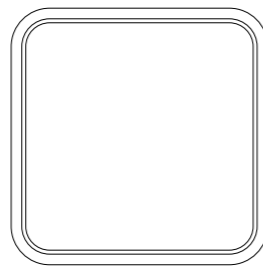

square low
walnut — GSMT002
cm 58 x 58 | h. cm 41
Lloyd square tray
+ frame n°6 on top
(code GSTV545)

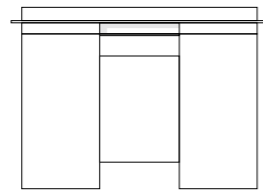

square low
ziricote — GSMT007
cm 58 x 58 | h. cm 41
Lloyd square tray
+ frame n°6 on top
(code GSTV545)





LLOYD SQUARE TABLE

Materials: leather and dark-stained
Canaletto walnut wood.
Provided with inox decorative feet.
Custom sizes available on request.

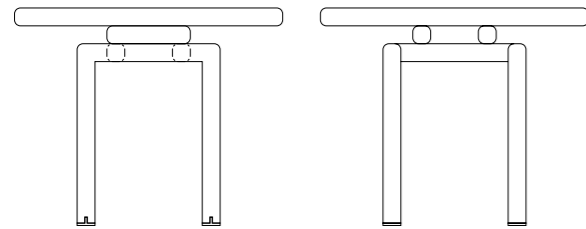
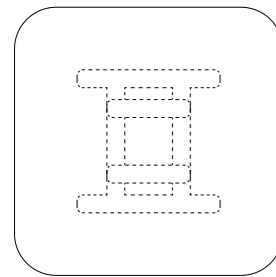

GSMT055
cm 90 x 90 | h. cm 75



LLOYD CONSOLE

Materials: leather and dark-stained
Canaletto walnut wood.
Provided with inox decorative feet.
Custom sizes available on request.

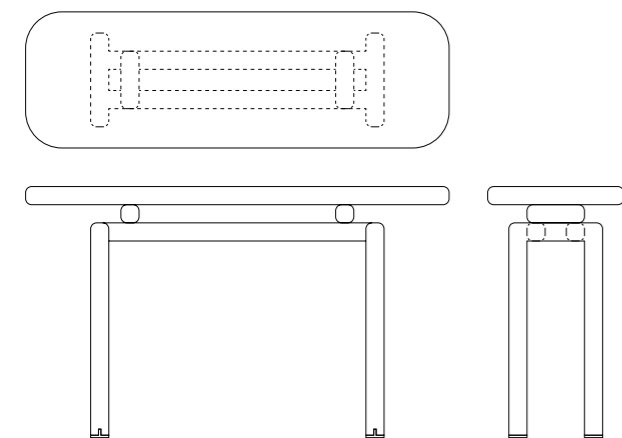

GSMC033
cm 140 x 45 | h. cm 83





NEWS PRESENTED IN SEPTEMBER 2020

LLOYD RECTANGULAR TRAYS

Partially leather-covered wood structure
available with walnut or wenge finish.
Custom sizes available on request.

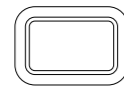

rectangular n°1
GSTV530
cm 26 x 18 | h. cm 3.5

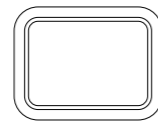

rectangular n°2
GSTV531
cm 34 x 26 | h. cm 3.5

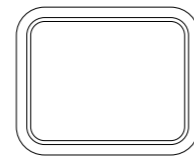

rectangular n°3
GSTV532
cm 42 x 34 | h. cm 3.5

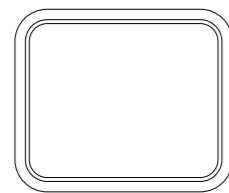

rectangular n°4
GSTV533
cm 50 x 42 | h. cm 3.5

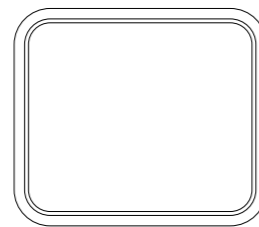

rectangular n°5
GSTV534
cm 58 x 50 | h. cm 3.5

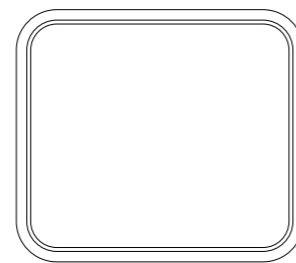

rectangular n°6
GSTV535
cm 66 x 58 | h. cm 3.5





LLOYD RECTANGULAR TRAYS + FRAME

Partially leather-covered wood structure
available with walnut or wenge finish.
Custom sizes available on request.



rectangular n°1
GSTV550
cm 26 x 18 | h. cm 6

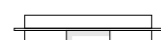

rectangular n°2
GSTV551
cm 34 x 26 | h. cm 6

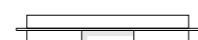
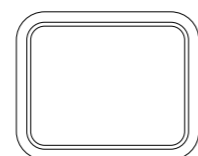

rectangular n°3
GSTV552
cm 42 x 34 | h. cm 6

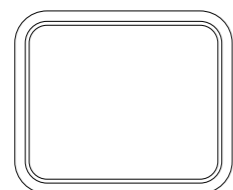

rectangular n°4
GSTV553
cm 50 x 42 | h. cm 6

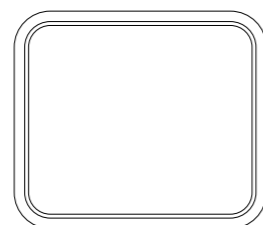

rectangular n°5
GSTV554
cm 58 x 50 | h. cm 6

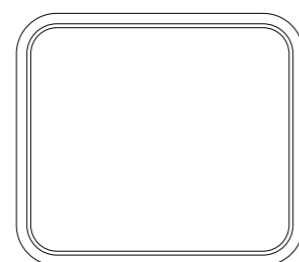

rectangular n°6
GSTV555
cm 66 x 58 | h. cm 6

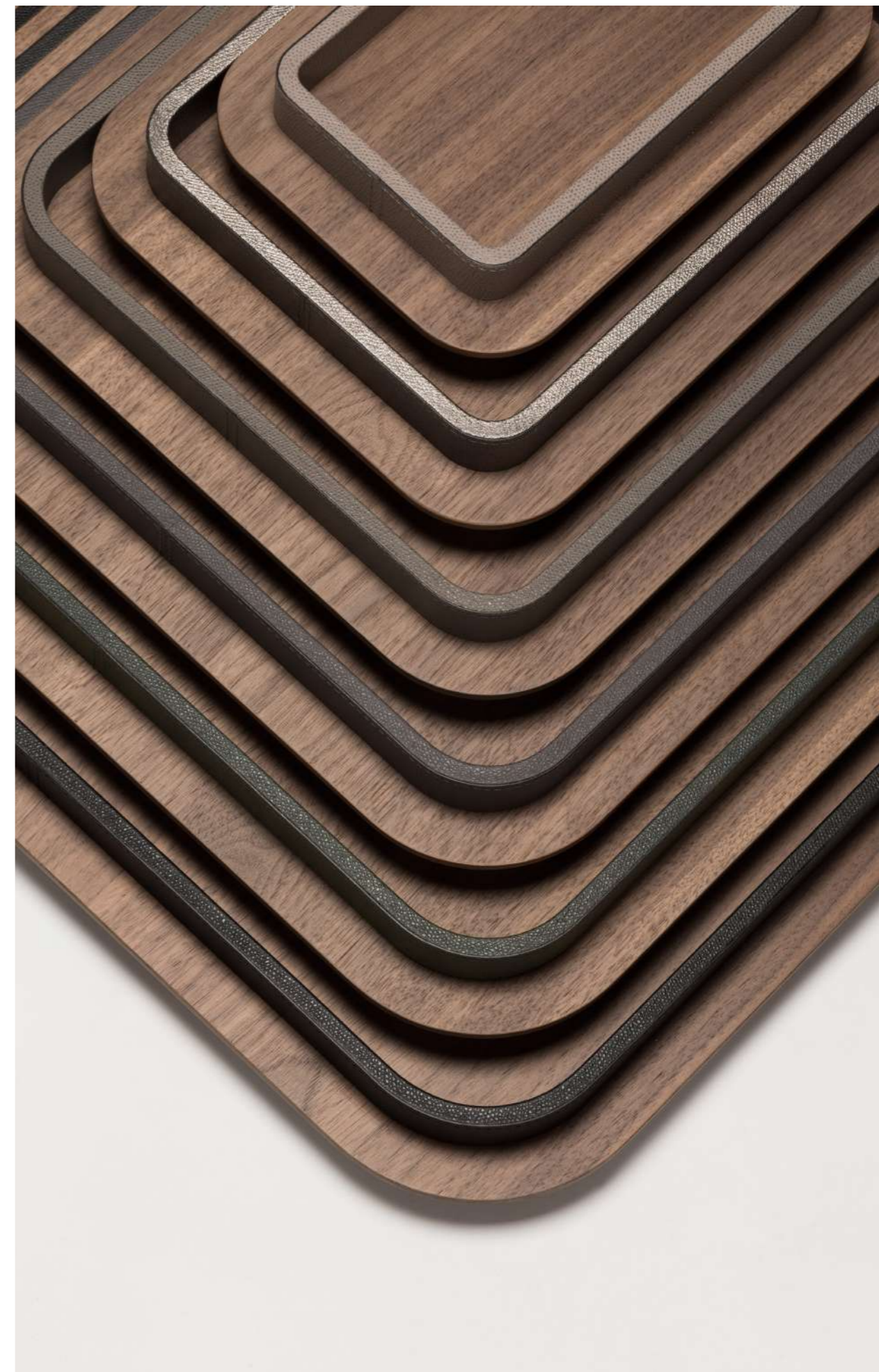



LLOYD SQUARE TRAYS

Partially leather-covered wood structure
available with walnut or wenge finish.
Custom sizes available on request.



square n°1
GSTV520
cm 18 x 18 | h. cm 3.5

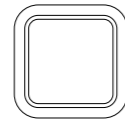

square n°2
GSTV521
cm 26 x 26 | h. cm 3.5

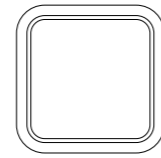

square n°3
GSTV522
cm 34 x 34 | h. cm 3.5

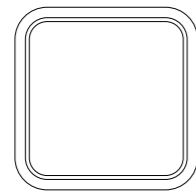

square n°4
GSTV523
cm 42 x 42 | h. cm 3.5

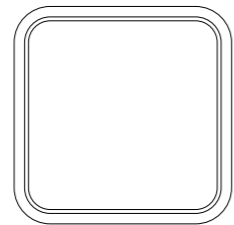

square n°5
GSTV524
cm 50 x 50 | h. cm 3.5

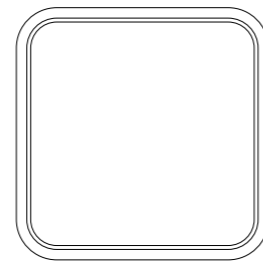

square n°6
GSTV525
cm 58 x 58 | h. cm 3.5





LLOYD
SQUARE TRAYS
+ FRAME

Partially leather-covered wood structure
available with walnut or wenge finish.
Custom sizes available on request.



square n°1
GSTV540
cm 18 x 18 | h. cm 6

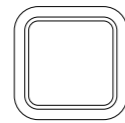

square n°2
GSTV541
cm 26 x 26 | h. cm 6

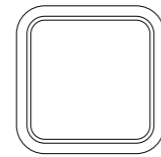

square n°3
GSTV542
cm 34 x 34 | h. cm 6

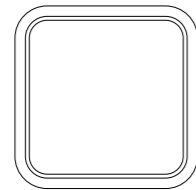

square n°4
GSTV543
cm 42 x 42 | h. cm 6

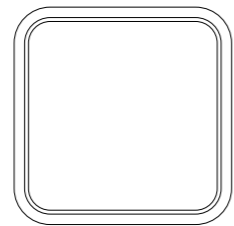

square n°5
GSTV544
cm 50 x 50 | h. cm 6

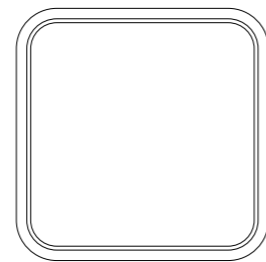

square n°6
GSTV545
cm 58 x 58 | h. cm 6





LLOYD
MARBLE
SQUARE TRAYS
+ FRAME

Travertine structure with brushed
burnished bronze frame.
Custom sizes available on request.

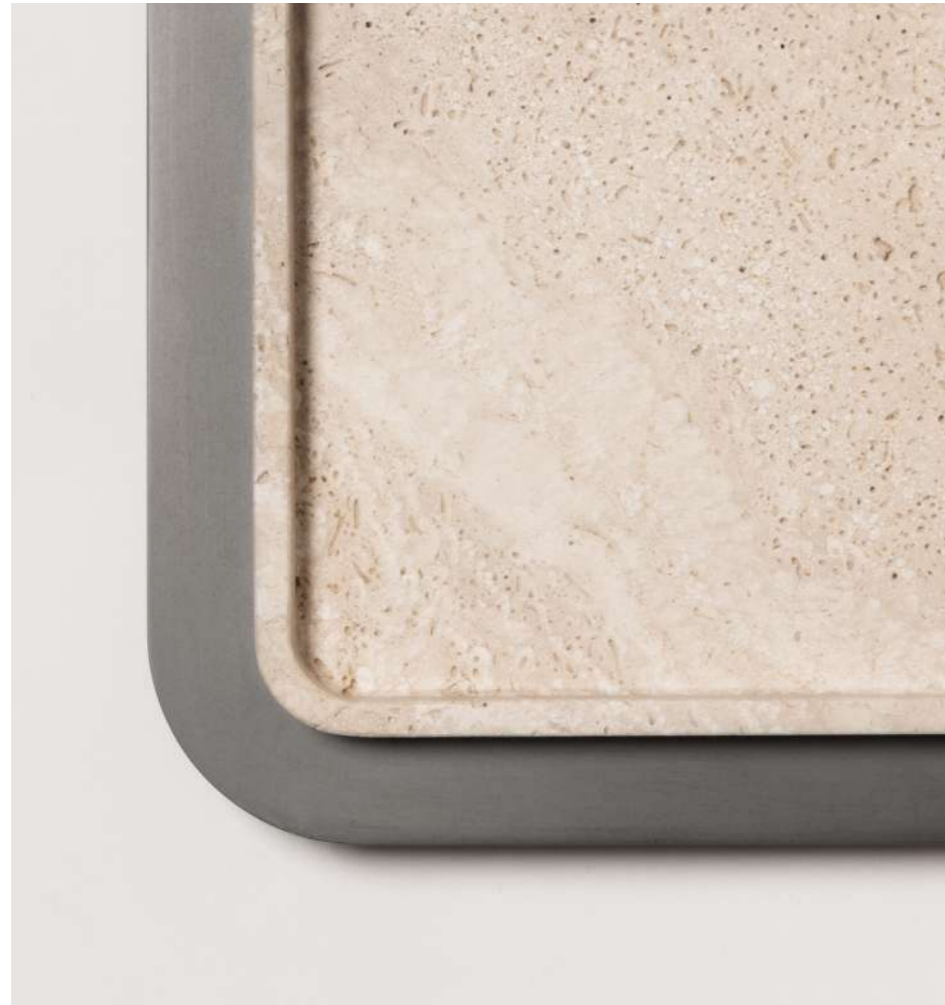

square n°1
GSTV540M
cm 18 x 18 | h. cm 5

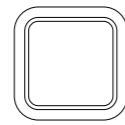

square n°2
GSTV541M
cm 26 x 26 | h. cm 5

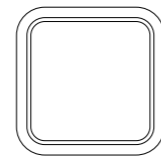

square n°3
GSTV542M
cm 34 x 34 | h. cm 5



LLOYD RECTANGULAR BOXES

Partially leather-covered
wood structure
available with walnut
or wenge finish.
Custom sizes available
on request.

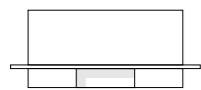
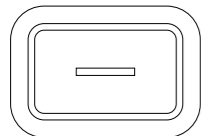

rectangular n°1
GSHB550
cm 26 x 18 | h. cm 7

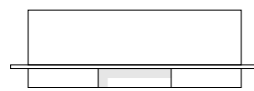
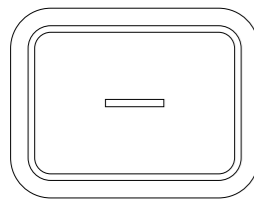

rectangular n°2
GSHB551
cm 34 x 26 | h. cm 7



LLOYD SQUARE BOXES

Partially leather-covered
wood structure
available with walnut
or wenge finish.
Custom sizes available
on request.

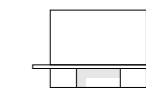
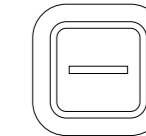

square n°1
GSHB540
cm 18 x 18 | h. cm 7

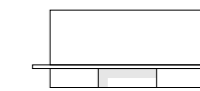
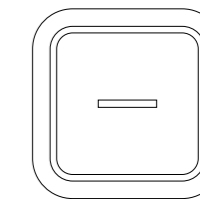

square n°2
GSHB541
cm 26 x 26 | h. cm 7



LEATHER COLORS

PRINTED CALFSKIN GOLF

tanned in Italy • origin: Northern Europe • price category: A
waterproof, scratchproof



PRINTED CALFSKIN GOLF

tanned in Italy • origin: Northern Europe • price category: A
waterproof, scratchproof



PRINTED CALFSKIN PANAMA

tanned in Italy • origin: Northern Europe • price category: B
water-resistant, scratchproof

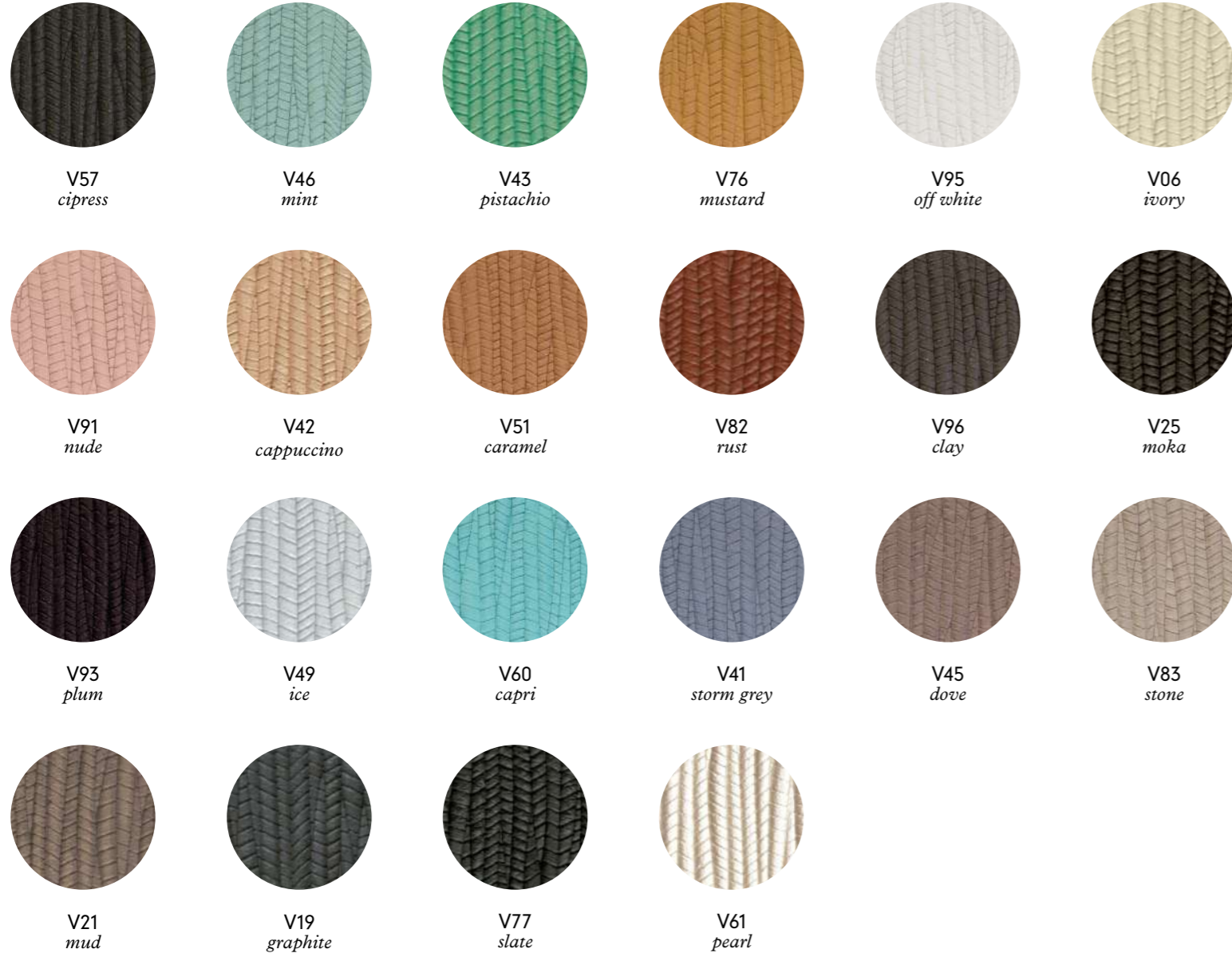

PRINTED CALFSKIN BELLAGIO

tanned in Italy • origin: Northern Europe • price category: B
water-resistant, scratchproof



PRINTED CALFSKIN CROCODILE

tanned in Italy • origin: Northern Europe • price category: A
waterproof, scratchproof



C02
green



C05
white



C38
mango



C06
ivory



C42
cappuccino



C08
siena



C19
graphite



C41
storm grey



C60
capri



C12
royal blue



C13
red



C17
bordeaux



C37
light grey



C21
mud



C24
smoke



C09
brown



C20
black

PRINTED CALFSKIN SHAGREEN

tanned in Italy • origin: Northern Europe • price category: B
water-resistant and slightly resistant to scratches

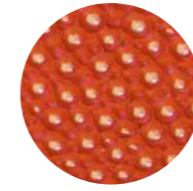

Z38
mango

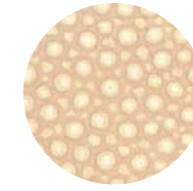

Z06
ivory

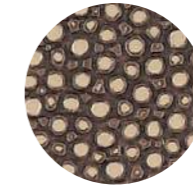

Z30
tobacco

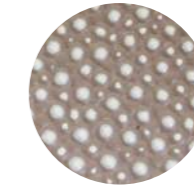

Z96
clay



Z25
moka

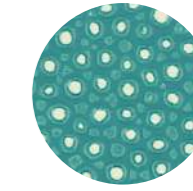

Z10
light blue



Z12
royal blue

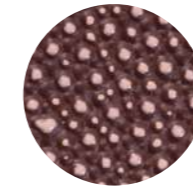

Z17
bordeaux

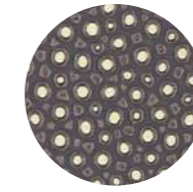

Z21
mud



Z20
black

PRINTED CALFSKIN WILD BOAR

tanned in Italy • origin: Northern Europe • price category: A
waterproof, scratchproof



PRINTED CALFSKIN WILD DEER

tanned in Italy • origin: Northern Europe • price category: A
water-resistant and slightly resistant to scratches



NAPPA

tanned in Italy • origin: Northern Europe • price category: A
water-resistant and slightly resistant to scratches



CALFSKIN PONY

tanned in Italy • origin: Northern Europe • price category: B
waterproof



SUEDE

tanned in Italy • origin: Northern Europe • price category: A
scratchproof



PRINTED CALFSKIN CLOUDS



tanned in Italy • origin: Northern Europe • price category: C
not waterproof

Calfskin with black base and partial gold foil application featuring a unique mottled effect.

PRINTED CALFSKIN FROST



tanned in Italy • origin: Northern Europe • price category: C
water-resistant

Calf skin with metal foil application. It features a pyrite-like appearance and is soft to the touch.

SHEARLING



tanned in Italy • origin: Italy • price category: SHEARLING
not waterproof

OTHER
FINISHES

WOOD FINISHES



DARK WALNUT



WENGE



ZIRCOTE*

MARBLE FINISHES



TRAVERTINO

Choose from 3 standard finishes or inquire about custom options.

*AVAILABLE ONLY IF SPECIFIED ON THE PRODUCT'S SHEET.

Zircote is a precious exotic wood (origin: Central America) characterized by an irregular dark veining that almost looks like a decorative motif.

Choose this standard finish or inquire about custom options.

ADDITIONAL
CUSTOM FINISHES

ADDITIONAL METAL FINISHES

Choose from 3 standard finishes or inquire about custom options.



POLISHED CHROME

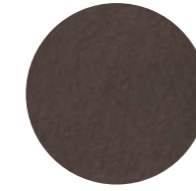

BRUSHED BRONZE



BRUSHED BRASS

ADDITIONAL MARBLE FINISHES

Choose from 4 standard finishes or inquire about custom options.



ARABESCATO WHITE

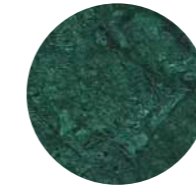

GREEN GUATEMALA

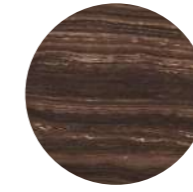

ERAMOSA BROWN



BLACK PORTORO

ADDITIONAL LACQUERED WOOD FINISHES

Choose from 4 standard finishes or inquire about custom options.

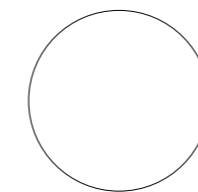

WHITE

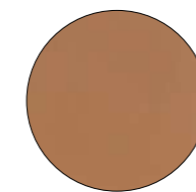

CAPPUCCINO

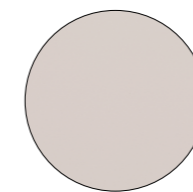

LIGHT GREY

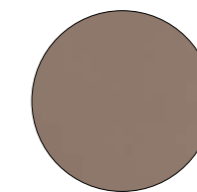

MUD

FRANCESCO BALZANO
×
GIOBAGNARA

UPDATE
FEBRUARY 2021 — SEPTEMBER 2020



GIORGIO BAGNARA, FOUNDER AND CEO OF GIOBAGNARA

Born into a family renowned for cultivating for three generations the art of living, Giorgio Bagnara became passionate about his calling at a very early age. In the late Nineties, after noticing that leather from the fashion industry was not considered enough as material for home accessories, he founded GIOBAGNARA with the goal of applying it to a complete collection. Along with his wife, Vanessa, he decided to move his design studios and workshops in the old docks of the Port of Genoa where, surrounded by the essence and beauty of that location, the company took a significant step forward.

GIOBAGNARA

A brand that is distinctive for elegantly designed creations that express luxury without ostentation, available in an uncommon and virtually limitless color palette of leathers and suede, and crafted to the highest standards using both traditional know-how and leading-edge technology. This approach to tradition and modernity led Giorgio Bagnara to experiment: he constantly pushes technical limits in his quest for objects that are both beautiful and relevant, and in doing so relies on the skills of the company's craftspeople. Very quickly, GIOBAGNARA became renowned for its expertise, and its founder became a partner of choice for a large number of interior decorators and yacht and jet designers who called upon his know-how for special commissions. In 2015, Giorgio Bagnara expanded its leather portfolio with the acquisition of the saddle leather specialist Rabitti 1969. Today, nearly two decades after its founding, GIOBAGNARA has one of the most comprehensive offers of leather home accessories on the market and is preparing to open a fresh chapter in its history.



FRANCESCO BALZANO

Francesco Balzano was born and grew up in Paris, yet his visual culture is imprinted with the images of Venice, Florence, Rome and Capri – where he used to spend his summer holidays. He studied interior design and architecture, and then joined the famed studio of Joseph Dirand, working on prestigious projects. In 2018, he opened his own studio and started designing custom and limited editions of furniture pieces for art and design galleries all over the world, whilst continuing his work as interior architect for private clients.

Simplicity as a means to ultimate sophistication. The unparalleled mix of noble materials, pure lines and essential functions of everyday lifestyle. The singularity of each design conceived as a sort of monolithic, sculptural piece that stands the test of time. “My work is architectural and authentic; – says Francesco – it is a permanent tribute to the beauty of timeless things”.

OSSICLE COLLECTION

Ossicle is a collection that comprises monolithic seats, benches and tables crafted with a carefully selected range of leather and marble colors and finishes.

Their monumental volumes originate from both primal monolithic and contemporary minimal features entwined, while the lines are a reference to the "Jeu des Osselets", which has roots dating back to ancient Greece and Rome, reinterpreting it according to a modern visual and a sharp humour, creating the perfect balance between organic and pure geometric shapes.



OSSICLE
MARBLE
TRAYS

small — FBTV033
cm 28 x 22 | h. cm 3

large — FBTV038
cm 56 x 44 | h. cm 5

Custom sizes available
on request.



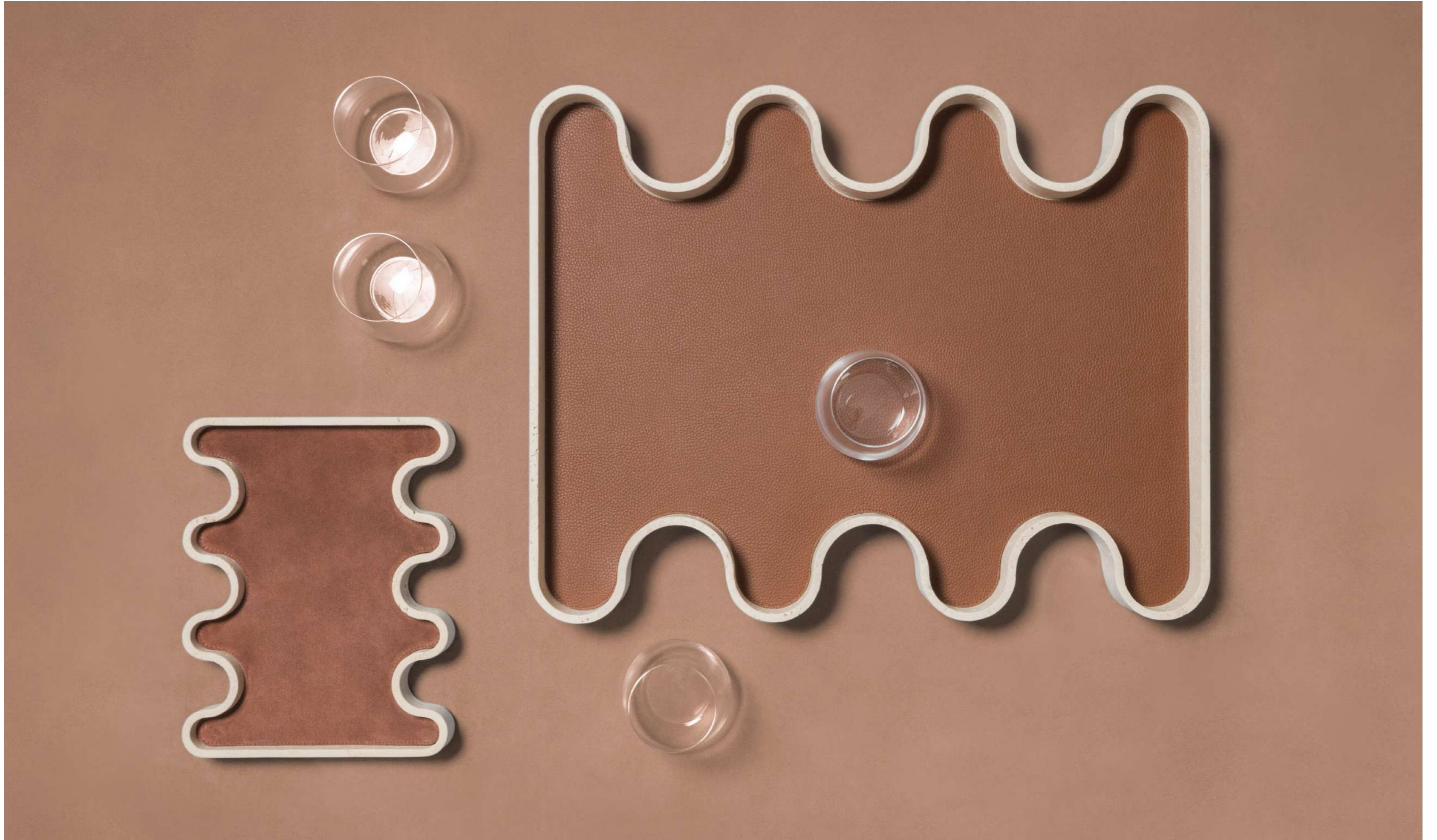



OSSICLE
TABLE
LAMP



FBLT704
cm 28 x 24 | h. cm 60
light bulb E27 100 W

Custom sizes available
on request.
Provided with a
Corian® removable
lampshade cover.

OSSICLE
LEATHER
ROUND
SIDE TABLE



FBMT094
Ø cm 90.5 | h. cm 75

FBMT095
Ø cm 130.5 | h. cm 75

FBMT096
Ø cm 160.5 | h. cm 75

Custom sizes available
on request.
Legs available in suede
only.

TABLE SEATING CHART

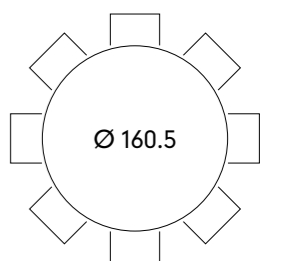
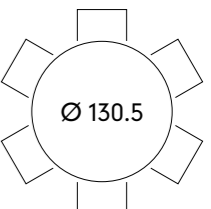
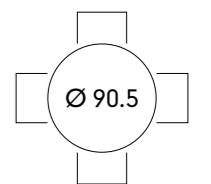



OSSICLE
LEATHER
ARMCHAIR



FBHS074
cm 60.5 x 70 | h. cm 65.5
seat height: cm 36 - 41

Custom sizes available on request.
Front leg available in suede only.



NEWS PRESENTED IN SEPTEMBER 2020



OSSICLE
LEATHER
STOOL

FBHS071
cm 56 x 40 | h. cm 45.5

Custom sizes available
on request.





OSSICLE
TRAVERTINE
STOOL



FBHS080
cm 56 x 40 | h. cm 45.5

Custom sizes available on request.

OSSICLE
LEATHER
CHAIR N°1



FBHS073
cm 90 x 40 | h. cm 63.5

Custom sizes available on request.

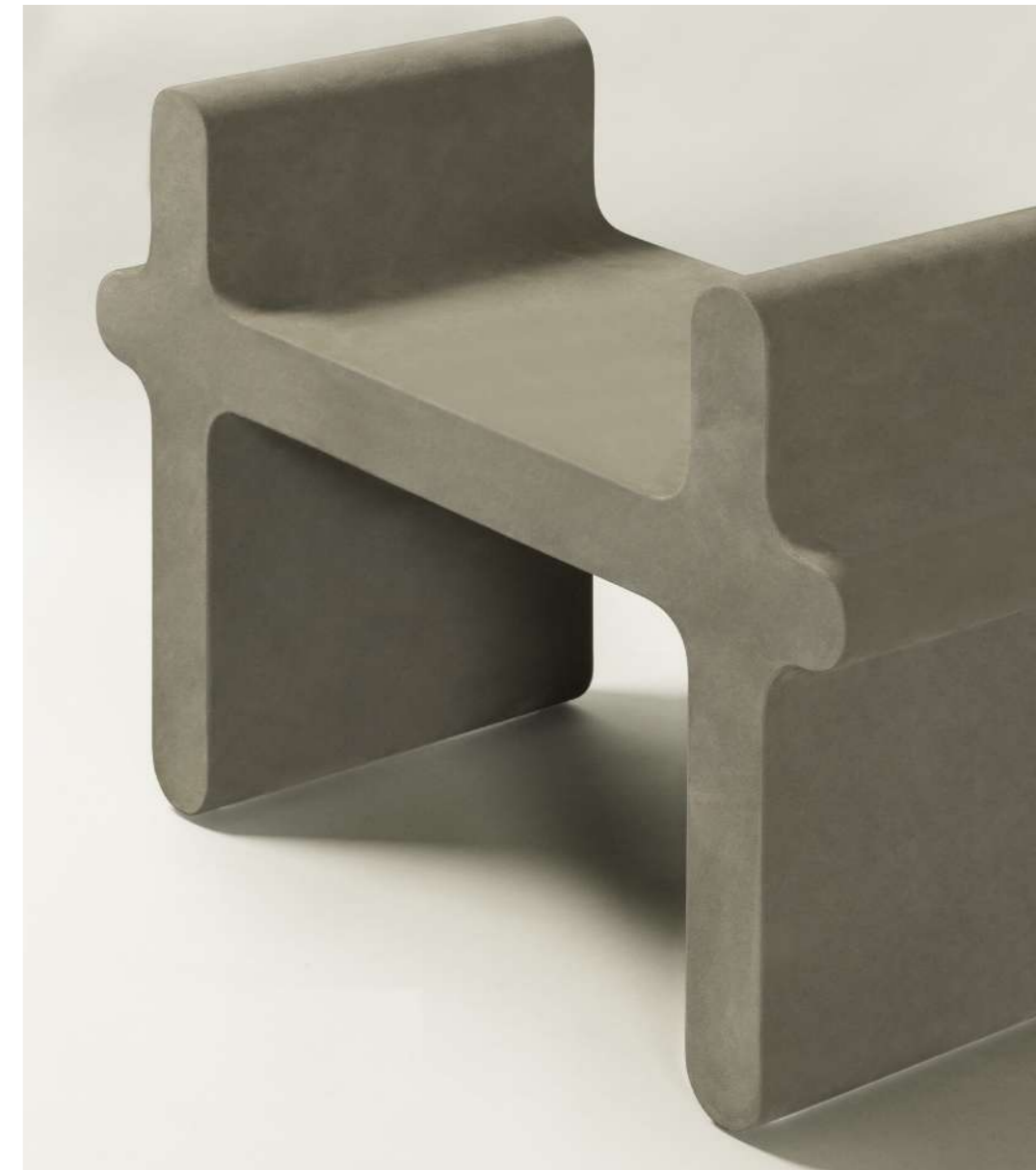



OSSICLE
TRAVERTINE
CHAIR N°1



FBHS082
cm 90 x 40 | h. cm 63.5

Custom sizes available on request.

OSSICLE
LEATHER
CHAIR N°2



FBHS077
cm 90 x 48 | h. cm 63.5

Custom sizes available on
request.
Legs available in suede
only.



OSSICLE
LEATHER
BENCH N°1



FBHS084
cm 160 x 40 | h. cm 53.5

Custom sizes available on request.

OSSICLE
LEATHER
BENCH N°2



FBHS079
cm 180 x 40 | h. cm 45.5

Custom sizes available on request.
Legs available in suede only.



OSSICLE
LEATHER
COFFEE TABLE



FBMT093
cm 160 x 60 | h. cm 35

Custom sizes available on request.
Legs available in suede only.



OSSICLE
LEATHER
CONSOLE



FBMC085
cm 200 x 35 | h. cm 86

Custom sizes available on request.
Legs available in suede only.

THE DESIGNER'S RECOMMENDED COMBINATIONS

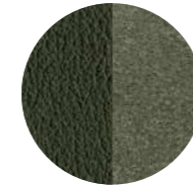

F02 + A02
loden green
loden green



F95 + A02
off-white
white



F06 + A06
ivory
ivory



F82 + A08
rust
siena



F96 + A21
clay
mud

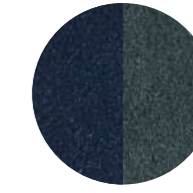

F33 + A31
ocean
petrol blue

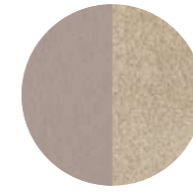

F83 + A37
stone
light grey

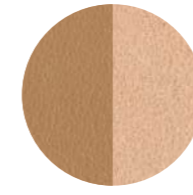

F42 + A42
cappuccino
cappuccino

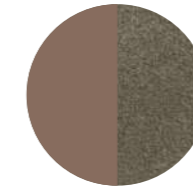

F21 + A69
mud
sage

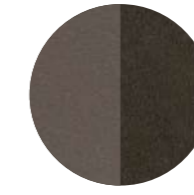

F24 + A80
smoke
musk



F65 + A82
antique rose
rust



F91 + A91
nude
nude

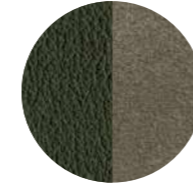

F02 + A69
loden green
sage

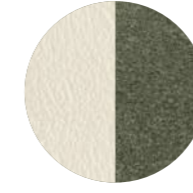

F95 + A02
off-white
loden green

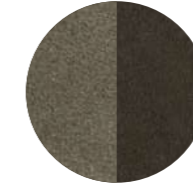

A69 + A80
sage
musk

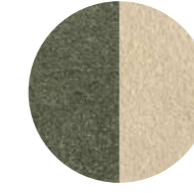

A02 + A06
loden green
ivory



F65 + A91
antique rose
nude

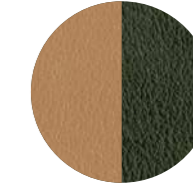

F42 + F02
cappuccino
loden green

LEATHER COLORS

PRINTED CALFSKIN GOLF

tanned in Italy • origin: Northern Europe • price category: A
waterproof, scratchproof



PRINTED CALFSKIN GOLF

tanned in Italy • origin: Northern Europe • price category: A
waterproof, scratchproof



NAPPA

tanned in Italy • origin: Northern Europe • price category: A
water-resistant and slightly resistant to scratches

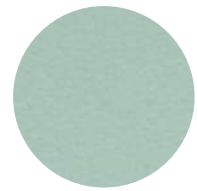

F46
mint

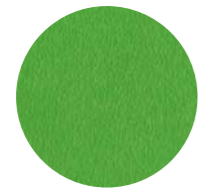

F26
apple green



F02
loden green



F76
mustard

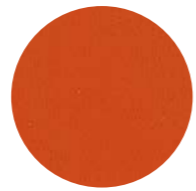

F04
orange

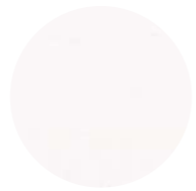

F05
white



F95
off white

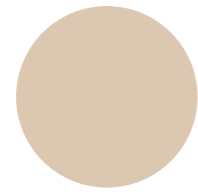

F06
ivory



F91
nude



F42
cappuccino



F51
caramel



F08
siena

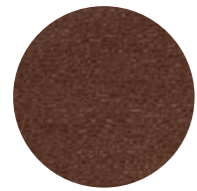

F82
rust



F09
brown



F10
light blue

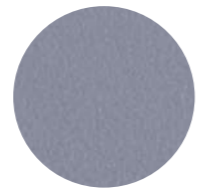

F41
storm grey



F60
capri

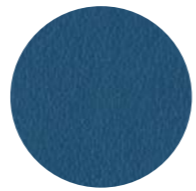

F68
denim

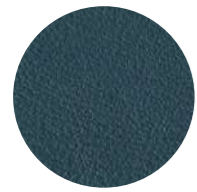

F31
petrol blue

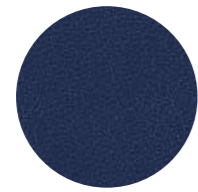

F12
royal blue

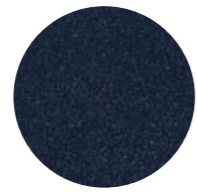

F33
ocean

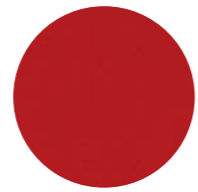

F13
red



F53
pink peony



F79
wine



F17
bordeaux



F65
antique rose



F93
plum



F83
stone

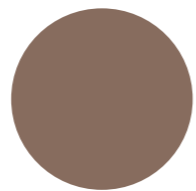

F21
mud

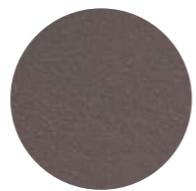

F24
smoke



F96
clay

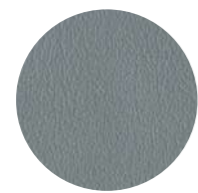

F71
rock



F19
graphite



F67
lava



F77
slate



F20
black

SUEDE

tanned in Italy • origin: Northern Europe • price category: A
scratchproof

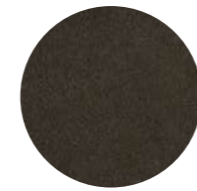

A80
musk

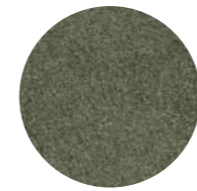

A02
loden green

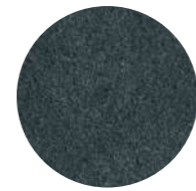

A31
petrol blue

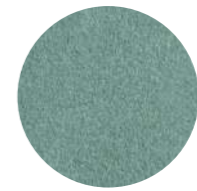

A46
mint

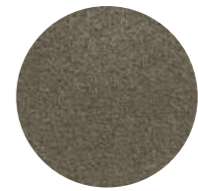

A69
sage



A44
terracotta



A05
white



A06
ivory



A42
cappuccino



A91
nude



A76
mustard

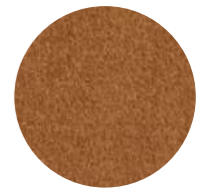

A30
tobacco



A08
siena

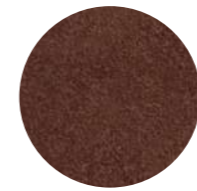

A82
rust



A47
nut

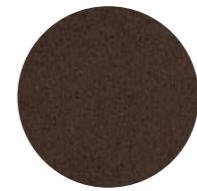

A75
chocolate



A09
brown



A66
sky

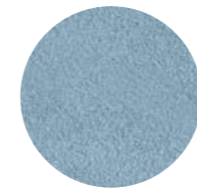

A92
wave

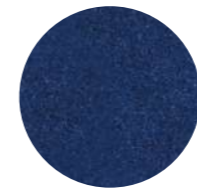

A32
ultramarine

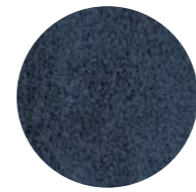

A12
royal blue



A33
ocean



A89
feather

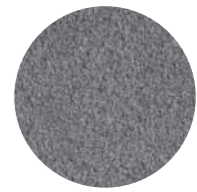

A19
graphite

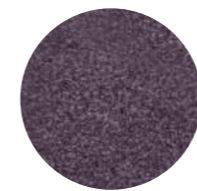

A16
violet

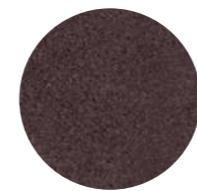

A93
plum

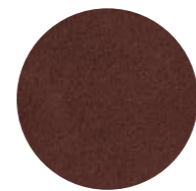

A17
bordeaux



A13
red

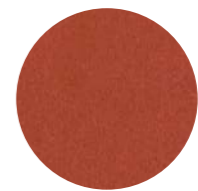

A62
papaya



A21
mud

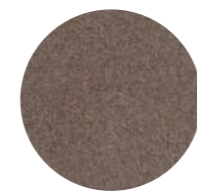

A24
smoke

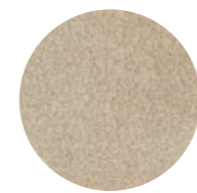

A37
light grey



A18
grey



A67
lava



A20
black

PRINTED CALFSKIN WILD BOAR

tanned in Italy • origin: Northern Europe • price category: A
waterproof, scratchproof

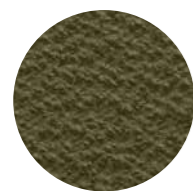

B98
olive green



B57
cipress



B01
acid green



B76
mustard



B38
mango



B95
off white



B42
cappuccino

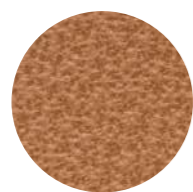

B51
caramel



B96
clay



B09
brown



B49
ice

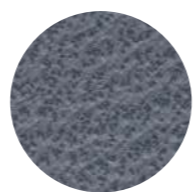

B41
storm grey



B33
ocean



B59
garnet



B17
bordeaux



B83
stone



B37
light grey

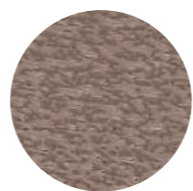

B21
mud

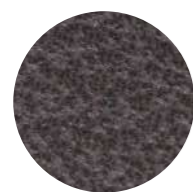

B67
lava



B77
slate



B20
black

PRINTED CALFSKIN WILD DEER

tanned in Italy • origin: Northern Europe • price category: A
water-resistant and slightly resistant to scratches

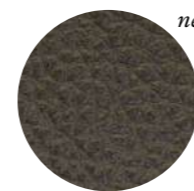

H57
cipress

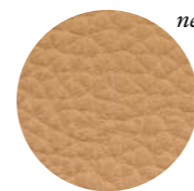

H42
cappuccino



H95
off white

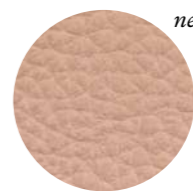

H91
nude

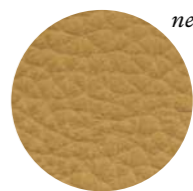

H76
mustard



H08
siena



H25
moka

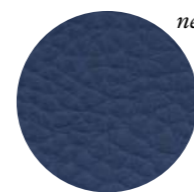

H12
royal blue

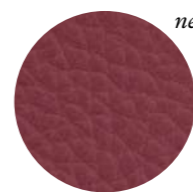

H17
bordeaux

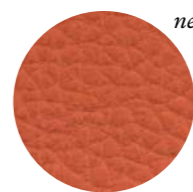

H62
papaya



H24
smoke

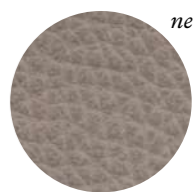

H21
mud

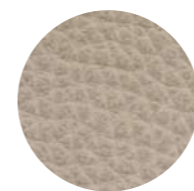

H83
stone



H37
light grey

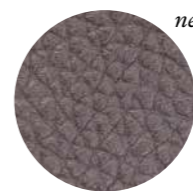

H67
lava



H93
plum



H20
black

R A B I T T I

I 9 6 9

by GIOBAGNARA

UPDATE

FEBRUARY 2021 — SEPTEMBER 2020



**GIORGIO BAGNARA,
FOUNDER AND CEO
OF GIOBAGNARA**

Born into a family renowned for cultivating for three generations the art of living, Giorgio Bagnara became passionate about his calling at a very early age. In the late Nineties, after noticing that leather from the fashion industry was not considered enough as material for home accessories, he founded GIOBAGNARA with the goal of applying it to a complete collection. As time passed, he established numerous partnerships with names in the field of design, such as the one with Stéphane Parmentier, who was appointed as creative director of the GIOBAGNARA brands in 2017. Along with his wife, Vanessa, he decided to move his design studios and workshops in the old docks of the Port of Genoa where, surrounded by the essence and beauty of that location, the company took a significant step forward.

RABITTI1969

In 2015, GIOBAGNARA acquired the famous Italian saddle leather specialist RABITTI. Rudi Rabitti, who launched the company in Milan in 1969, was a pioneer: his was the first brand to offer a wide array of home accessories in this type of leather. He quickly won an international reputation. With RABITTI1969, GIOBAGNARA is expanding its offer, both by revisiting the house archives and creating new collections. Because saddle leather is thick and particularly sturdy, it needs no reinforcement and makes it possible to create objects entirely in leather.



CRUZ STOOL

Laminated wood structure
boasting a rolled saddle leather
insert on top.

Design by Simone Fanciullacci.

Wood finishes available:
natural / wenge.



9218
Ø cm 37 | h. cm 40





BELVEDERE CONSOLE

Solid wood top and base made
of burnished aluminium
and featuring saddle leather
decorative bands.

Design by Simone Fanciullacci.

Wood finishes available:
natural / wenge.



9005
cm 140 x 38 | h. cm 85





CLIFF VASES

Blown amber-colored glass
structure with saddle leather
and travertine inserts.

Design by Simone Fanciullacci.



low large — 6400
Ø cm 18 | h. cm 15

high small — 6401
Ø cm 10 | h. cm 30

PALÙ
STORAGE BASKETS

Braided multicolor saddle leather storage baskets with handles.

Design by Federica Biasi.



low small — 5470
Ø cm 36.5 | h. cm 40.5

tall large — 5471
Ø cm 40.5 | h. cm 53



RECOMMENDED COMBINATIONS FOR THE PALÙ COLLECTION

All leathers are provided with a water resistant finish. Thanks to an exclusive treatment, the saddle leather dries perfectly, doesn't lose its characteristics and doesn't leave color stains after being in contact with water. Ideal for towel baskets.

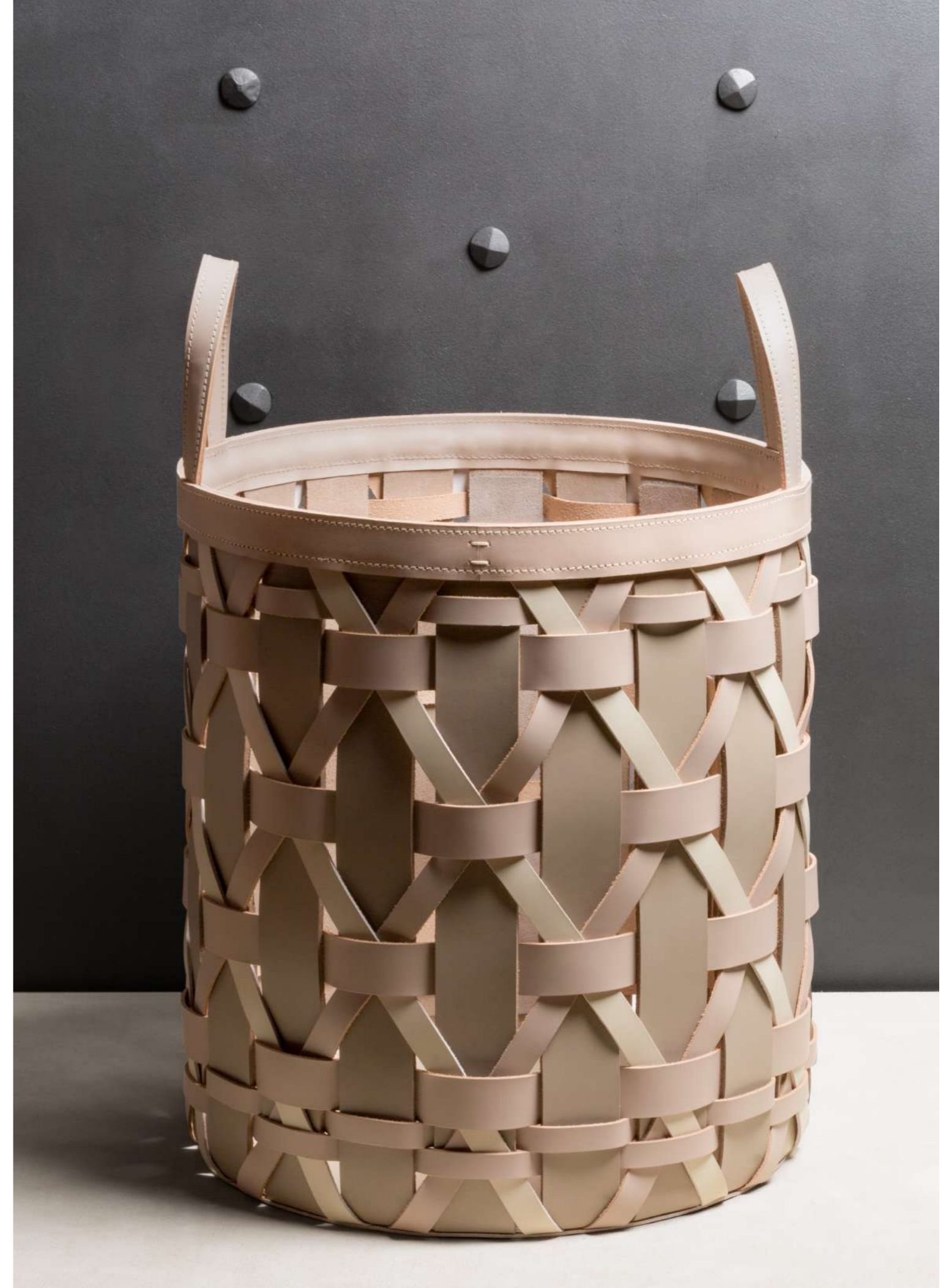
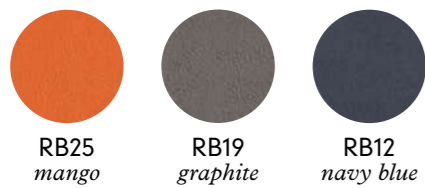

COPENHAGEN STORAGE BASKETS

Saddle leather storage baskets.

Design by Gio Tiroto.



small — 5570
cm 29.5 x 26.5 | h. 29.5

large — 5571
cm 45 x 31 | h. 34.5



**COPENHAGEN
STORAGE BASKET
WITH DIVIDERS**

Saddle leather storage basket.
Provided with 6 dividers.

Design by Gio Tiroto.



large high with dividers — 5572
cm 45 x 30 | h. 51.5





WACO
SHOEHORN

Saddle leather shoehorn.



3807
cm 42 x 5



LEATHERS



VEGETABLE TANNED
SADDLE LEATHER
COLOUR CHART



All leathers are provided with a water resistant finish. Thanks to an exclusive treatment, the saddle leather dries perfectly, doesn't lose its characteristics and doesn't leave color stains after being in contact with water. Ideal for towel baskets.

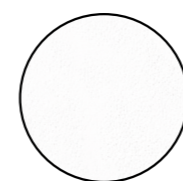

RB29
white



RB18
light grey

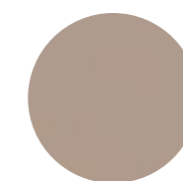

RB20
mud

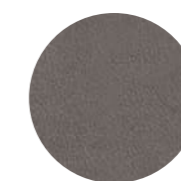

RB19
graphite



RB21
black

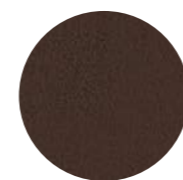

RB09
moka

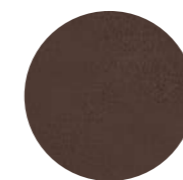

RB22
brown



RB24
cognac



RB30
natural



RB17
cream



RB36
yellow

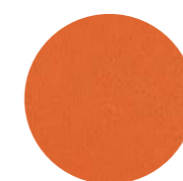

RB25
mango

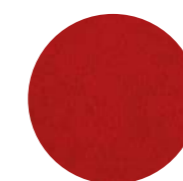

RB23
red



RB12
navy blue



RB14
loden green



SADDLE LEATHER RECOMMENDED COMBINATIONS FOR THE PALÙ BASKETS



All leathers are provided with a water resistant finish. Thanks to an exclusive treatment, the saddle leather dries perfectly, doesn't lose its characteristics and doesn't leave color stains after being in contact with water. Ideal for towel baskets.

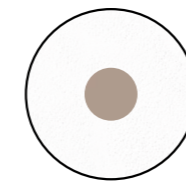

RB29 + RB20
white
mud

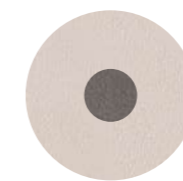

RB18 + RB19
light grey
graphite

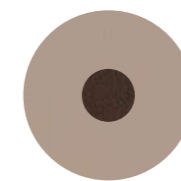

RB20 + RB09
mud
moka

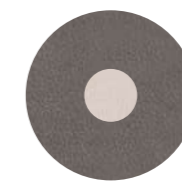

RB19 + RB18
graphite
light grey

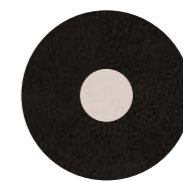

RB21 + RB18
black
light grey

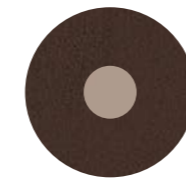

RB09 + RB20
moka
mud

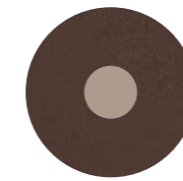

RB22 + RB20
brown
mud

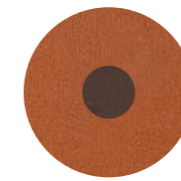

RB24 + RB22
cognac
brown

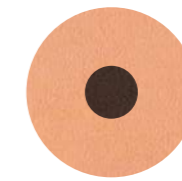

RB30 + RB09
natural
moka

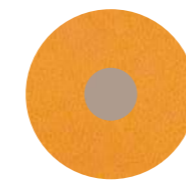

RB36 + RB20
yellow
mud



RB25 + RB29
mango
white



RB23 + RB18
red
light grey

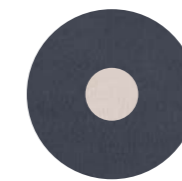

RB12 + RB18
navy blue
light grey

R U D I
finest regenerated leather
HANDMADE IN ITALY

UPDATE
FEBRUARY 2021 — SEPTEMBER 2020

RUDI: Who, What, Where, When, Why and How?

In 1996, **Rudi Rabitti trademarked** in Milan **Tecnocuoio®**, a composite material, both **UV-resistant** and **water-resistant**, made from leather castoffs from its own production.

The company was well ahead of its time in adhering to a **zero-waste philosophy** that was both **eco-friendly** and **functional**.

While the company has focused on contract work, the acquisition of the brand in 2017 by Giobagnara resulted in the decision to create two separate brands: Rabitti 1969 for products made from genuine leather; and **RUDI** for items created from regenerated leather.

Giobagnara sees an opportunity to introduce **RUDI** products to a wider audience. With the creative direction of the Italian designer **Simone Fanciullacci**, since 2019, the company is pursuing a more decorative approach, able to explore new languages and enhance the properties of **Tecnocuoio®**. It is enlarging the number of product categories and expanding the number of aesthetic solutions for **interior design projects**, **high-end Ho.Re.Ca** and the **yacht interiors** market.

The objective of **RUDI** is to eliminate all leather waste and create beautiful objects from recycled materials that are perfect both for **indoors** and **outdoors**, able to generate an elegant yet casual atmosphere where simple lines play with complex patterns, looking for practical yet always original solutions.

RUDI can now be viewed as more than just a brand name. It is a **model of Italian ingenuity** where Giobagnara has brought together all of its know-how and creativity in an effort to raise ecological awareness.

A HANDMADE TRADITION

RUDI creations are **made entirely by hand** with the masterly skills of our craftsmen who, thanks to their experience, take care of everything down to the smallest detail to guarantee **durable** and **impeccable products**, all in accordance with the original tradition of Italian finest handmade leather goods combined with the use of cut-edge technology.



TECNOCUOIO®

Trademarked by the company in 1996, this innovative material is composed of **finely milled leather castoffs** tanned with vegetal extracts, natural latex (extract from the rubber tree) for bonding, natural fats, salts and natural coloring agents. After adding water, the mixture is pumped through a screen. After being dried, pressed and refined, one obtains a bonded leather fiber material via a process similar to that used in the production of paper. The result is a **high-quality regenerated leather** boasting elasticity that is both **UV-resistant** and **water-resistant**, and which features a perfectly smooth surface.

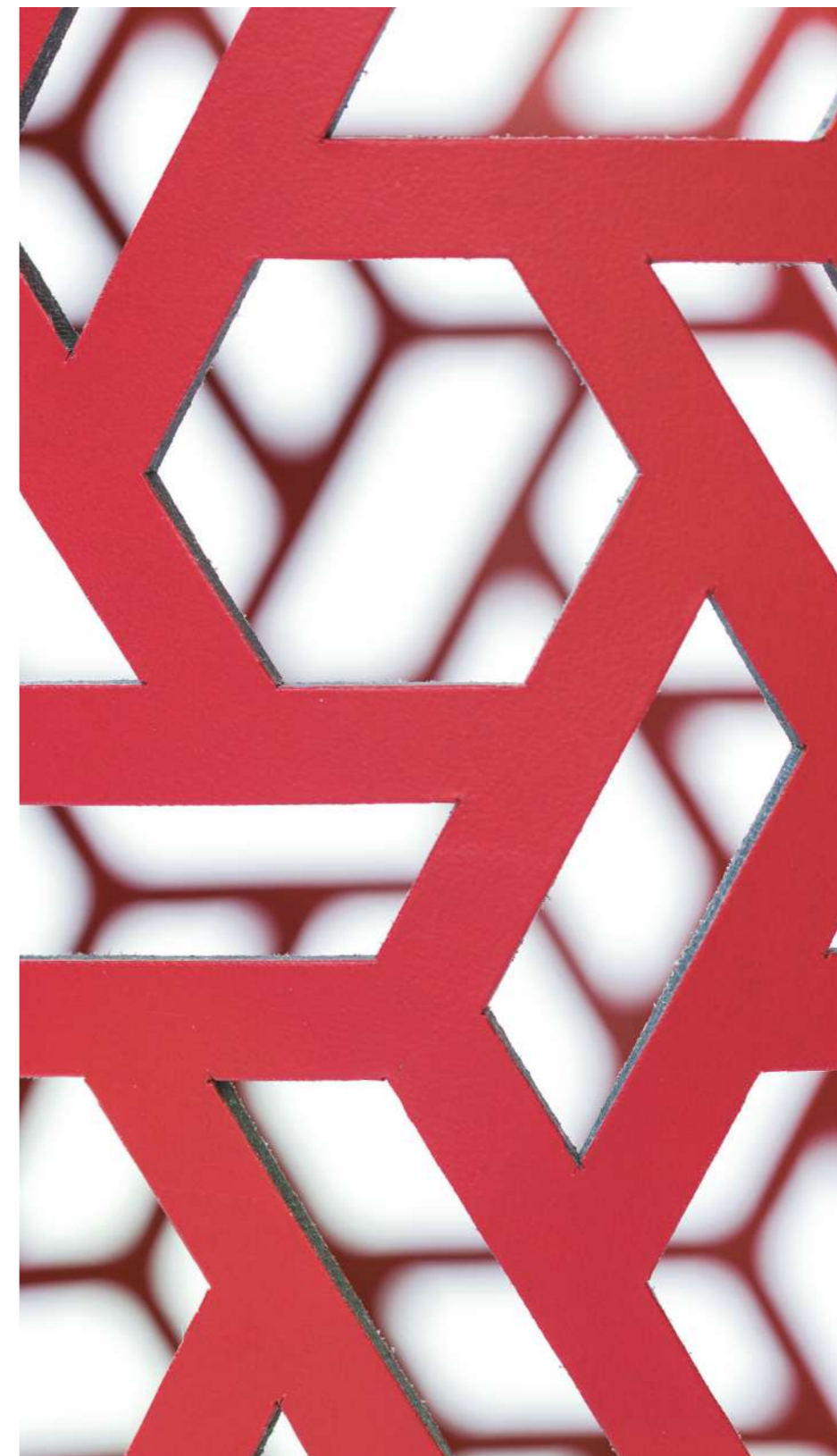

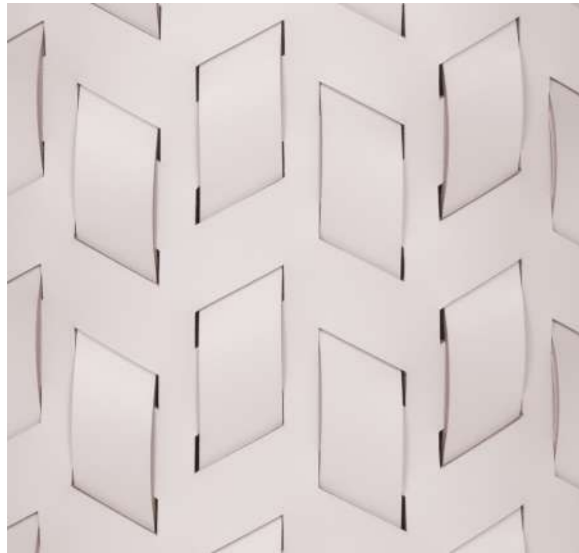

CANCUN BASKETS

The Cancun baskets are characterized by a weave that develops only through vertical dotted lines that, being cut diagonally, seem to chase one another on the surface, giving life to a design that reminds of the warm and a tad retro atmospheres of certain fabrics typical of Central America.

Finest regenerated reinforced leather structure with water-resistant and UV-resistant finish.
Ideal for laundry, towels, magazines or everyday objects.
Fit for both indoor and outdoor use.
Non-slip waterproof rubber base underneath.

It is possible to choose any color combination from our chart for the baskets' bicolor and tricolor versions.





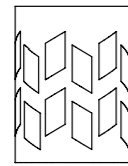

**CANCUN 4
ROUND**

monochrome
TCR5704
monochrome + lid
TCR5704LID
bicolor
TCR5704BIC
bicolor + lid
TCR5704BICLID

tricolor
TCR5704TRIC
tricolor + lid
TCR5704TRICLID

Ø cm 25 | h cm 30

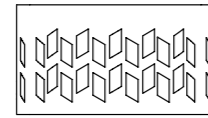

**CANCUN 6
ROUND**

monochrome
TCR5706
monochrome + lid
TCR5706LID
bicolor
TCR5706BIC
bicolor + lid
TCR5706BICLID

tricolor
TCR5706TRIC
tricolor + lid
TCR5706TRICLID

Ø cm 40 | h cm 22

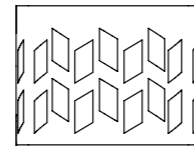

**CANCUN 9
ROUND**

monochrome
TCR5709
monochrome + lid
TCR5709LID
bicolor
TCR5709BIC
bicolor + lid
TCR5709BICLID

tricolor
TCR5709TRIC
tricolor + lid
TCR5709TRICLID

Ø cm 38 | h cm 30

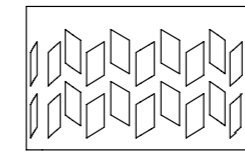

**CANCUN 10
ROUND**

monochrome
TCR5710
monochrome + lid
TCR5710LID
bicolor
TCR5710BIC
bicolor + lid
TCR5710BICLID

tricolor
TCR5710TRIC
tricolor + lid
TCR5710TRICLID

Ø cm 50 | h cm 30

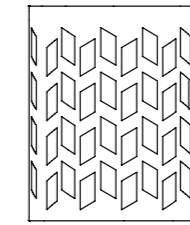

**CANCUN 12
ROUND**

monochrome
TCR5712
monochrome + lid
TCR5712LID
bicolor
TCR5712BIC
bicolor + lid
TCR5712BICLID

tricolor
TCR5712TRIC
tricolor + lid
TCR5712TRICLID

Ø cm 38 | h cm 48

Also available with the
addition of a fine linen
bag.

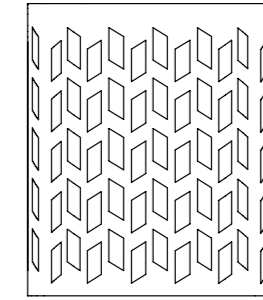

**CANCUN 13
ROUND**

monochrome
TCR5713
monochrome + lid
TCR5713LID
bicolor
TCR5713BIC
bicolor + lid
TCR5713BICLID

tricolor
TCR5713TRIC
tricolor + lid
TCR5713TRICLID

Ø cm 50 | h cm 60

Also available with the
addition of a fine linen
bag.

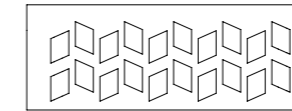

**CANCUN 15
RECTANGULAR**

monochrome
TCR5715
monochrome + lid
TCR5715LID

bicolor
TCR5715BIC
bicolor + lid
TCR5715BICLID

tricolor
TCR5715TRIC
tricolor + lid
TCR5715TRICLID

cm 63 x 45 | h cm 22.5

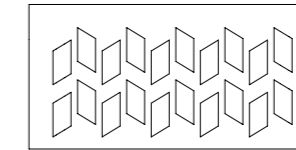

**CANCUN 16
RECTANGULAR**

monochrome
TCR5716
monochrome + lid
TCR5716LID

bicolor
TCR5716BIC
bicolor + lid
TCR5716BICLID

tricolor
TCR5716TRIC
tricolor + lid
TCR5716TRICLID

cm 63 x 45 | h cm 30

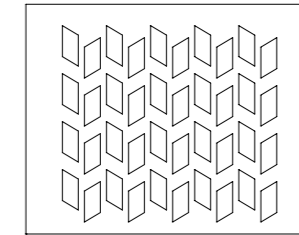

**CANCUN 17
RECTANGULAR**

monochrome
TCR5717
monochrome + lid
TCR5717LID

bicolor
TCR5717BIC
bicolor + lid
TCR5717BICLID

tricolor
TCR5717TRIC
tricolor + lid
TCR5717TRICLID

cm 63 x 45 | h cm 48.5

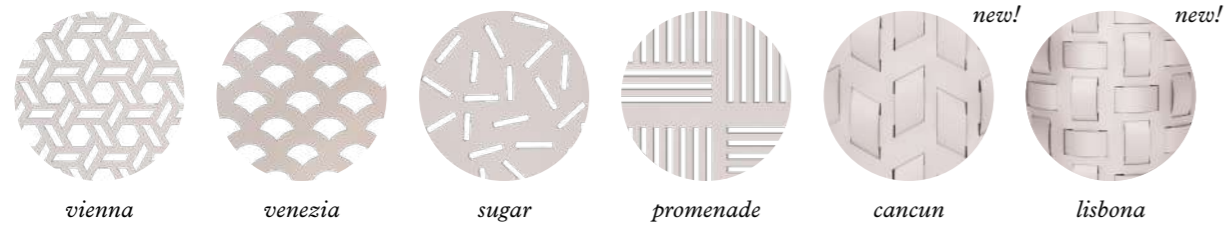

BINO
BIN / UMBRELLA STAND
WITH METAL

Coated metal structure
and finest regenerated
leather cover with water-resistant
and UV-resistant finish.

Available with a smooth surface
or with a pattern of choice among
Vienna, Venezia, Sugar, Promenade,
Cancun and Lisbona.

monochrome bin — TCR1225
Ø cm 23 | h cm 32

bicolor bin — TCR1225BIC
Ø cm 23 | h cm 32

tricolor bin — TCR1225TRIC
Ø cm 23 | h cm 32
available only for Cancun and Lisbona pattern

monochrome umbrella stand — TCR1227
Ø cm 27 | h cm 60.5

bicolor umbrella stand — TCR1227BIC
Ø cm 27 | h cm 60.5

tricolor umbrella stand — TCR1227TRIC
Ø cm 27 | h cm 60.5
available only for Cancun and Lisbona pattern



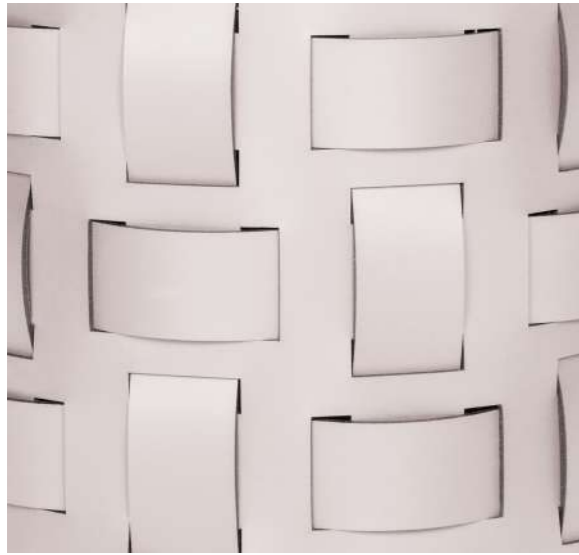

LISBONA BASKETS

The Lisbona baskets' design comes from the variation of a classic weave with vertical and horizontal bands in which, however, the overlays are hidden so as to create a surface similar to a mosaic.

The surface that acts as a frame for the bands acquires importance and, from simple background, it becomes a decorative element able to enhance the weave and its design.

Finest regenerated reinforced leather structure with water-resistant and UV-resistant finish.

Ideal for laundry, towels, magazines or everyday objects.

Fit for both indoor and outdoor use. Non-slip waterproof rubber base underneath.

It is possible to choose any color combination from our chart for the baskets' bicolor and tricolor versions.



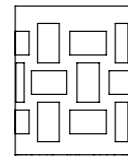

LISBONA 4 ROUND

monochrome
TCR5604
monochrome + lid
TCR5604LID
bicolor
TCR5604BIC
bicolor + lid
TCR5604BICLID

tricolor
TCR5604TRIC
tricolor + lid
TCR5604TRICLID

Ø cm 25 | h cm 30

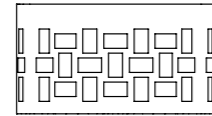

LISBONA 6 ROUND

monochrome
TCR5606
monochrome + lid
TCR5606LID
bicolor
TCR5606BIC
bicolor + lid
TCR5606BICLID

tricolor
TCR5606TRIC
tricolor + lid
TCR5606TRICLID

Ø cm 40 | h cm 22

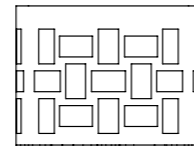

LISBONA 9 ROUND

monochrome
TCR5609
monochrome + lid
TCR5609LID
bicolor
TCR5609BIC
bicolor + lid
TCR5609BICLID

tricolor
TCR5609TRIC
tricolor + lid
TCR5609TRICLID

Ø cm 38 | h cm 30

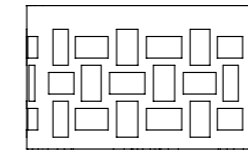

LISBONA 10 ROUND

monochrome
TCR5610
monochrome + lid
TCR5610LID
bicolor
TCR5610BIC
bicolor + lid
TCR5610BICLID

tricolor
TCR5610TRIC
tricolor + lid
TCR5610TRICLID

Ø cm 50 | h cm 30

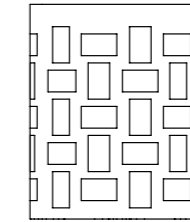

LISBONA 12 ROUND

monochrome
TCR5612
monochrome + lid
TCR5612LID
bicolor
TCR5612BIC
bicolor + lid
TCR5612BICLID

tricolor
TCR5612TRIC
tricolor + lid
TCR5612TRICLID

Ø cm 38 | h cm 48

Also available with the
addition of a fine linen
bag.

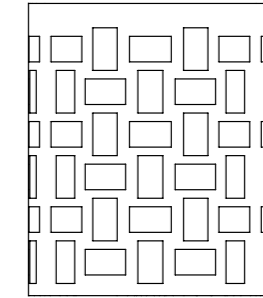

LISBONA 13 ROUND

monochrome
TCR5613
monochrome + lid
TCR5613LID
bicolor
TCR5613BIC
bicolor + lid
TCR5613BICLID

tricolor
TCR5613TRIC
tricolor + lid
TCR5613TRICLID

Ø cm 50 | h cm 60

Also available with the
addition of a fine linen
bag.



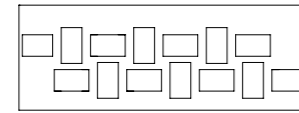

**LISBONA 15
RECTANGULAR**

monochrome
TCR5615
monochrome + lid
TCR5615LID

bicolor
TCR5615BIC
bicolor + lid
TCR5615BICLID

tricolor
TCR5615TRIC
tricolor + lid
TCR5615TRICLID

cm 63 x 45 | h cm 22.5

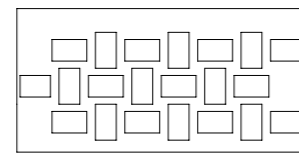

**LISBONA 16
RECTANGULAR**

monochrome
TCR5616
monochrome + lid
TCR5616LID

bicolor
TCR5616BIC
bicolor + lid
TCR5616BICLID

tricolor
TCR5616TRIC
tricolor + lid
TCR5616TRICLID

cm 63 x 45 | h cm 30

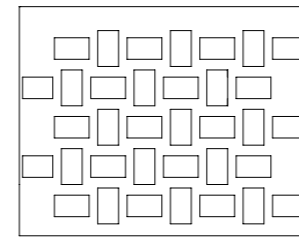

**LISBONA 17
RECTANGULAR**

monochrome
TCR5617
monochrome + lid
TCR5617LID

bicolor
TCR5617BIC
bicolor + lid
TCR5617BICLID

tricolor
TCR5617TRIC
tricolor + lid
TCR5617TRICLID

cm 63 x 45 | h cm 48.5



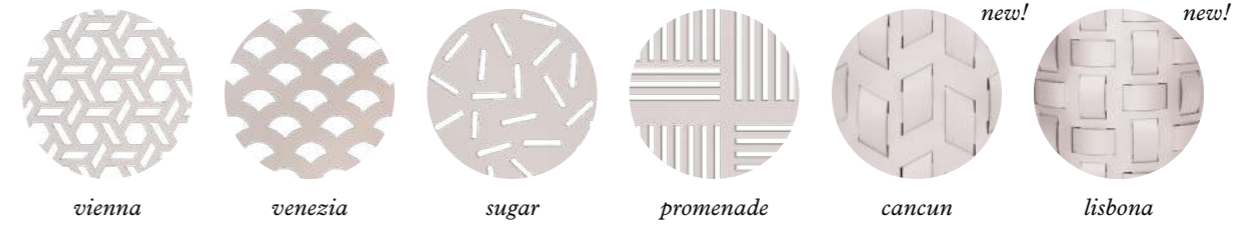

**BINO
BIN / UMBRELLA STAND
WITH METAL**

Coated metal structure and finest regenerated leather cover with water-resistant and UV-resistant finish.

Available with a smooth surface or with a pattern of choice among Vienna, Venezia, Sugar, Promenade, Cancun and Lisbona.

monochrome bin — TCR1225
Ø cm 23 | h cm 32

bicolor bin — TCR1225BIC
Ø cm 23 | h cm 32

tricolor bin — TCR1225TRIC
Ø cm 23 | h cm 32
available only for Cancun and Lisbona pattern

monochrome umbrella stand — TCR1227
Ø cm 27 | h cm 60.5

bicolor umbrella stand — TCR1227BIC
Ø cm 27 | h cm 60.5

tricolor umbrella stand — TCR1227TRIC
Ø cm 27 | h cm 60.5
available only for Cancun and Lisbona pattern







BABYLON HIGH TRAYS

Metal structure covered with overlaid TecnoCuio® discs.
Finest regenerated leather with water-resistant and UV-resistant finish.
It is possible to choose any color combination from our chart for the upstands' bicolor version.

monochrome small — TCR5046
Ø cm 16 | h cm 5.5

monochrome medium — TCR5047
Ø cm 22 | h cm 9.5

monochrome large — TCR5048
Ø cm 30 | h cm 14

bicolor small — TCR5046BIC
Ø cm 16 | h cm 5.5

bicolor medium — TCR5047BIC
Ø cm 22 | h cm 9.5

bicolor large — TCR5048BIC
Ø cm 30 | h cm 14





CHEVRON VALET TRAYS

Inner surface made of laminated wood and finest regenerated reinforced leather structure with water-resistant and UV-resistant finish. The juxtaposition of Tecno cuoio® and wood with unique textures generates a vibrant interplay of materials.

round small — TCR1165
Ø cm 13 | h cm 6

oval small — TCR1166
cm 23 x 13 | h cm 6

rectangular rounded large — TCR1167
cm 26 x 35 | h cm 6



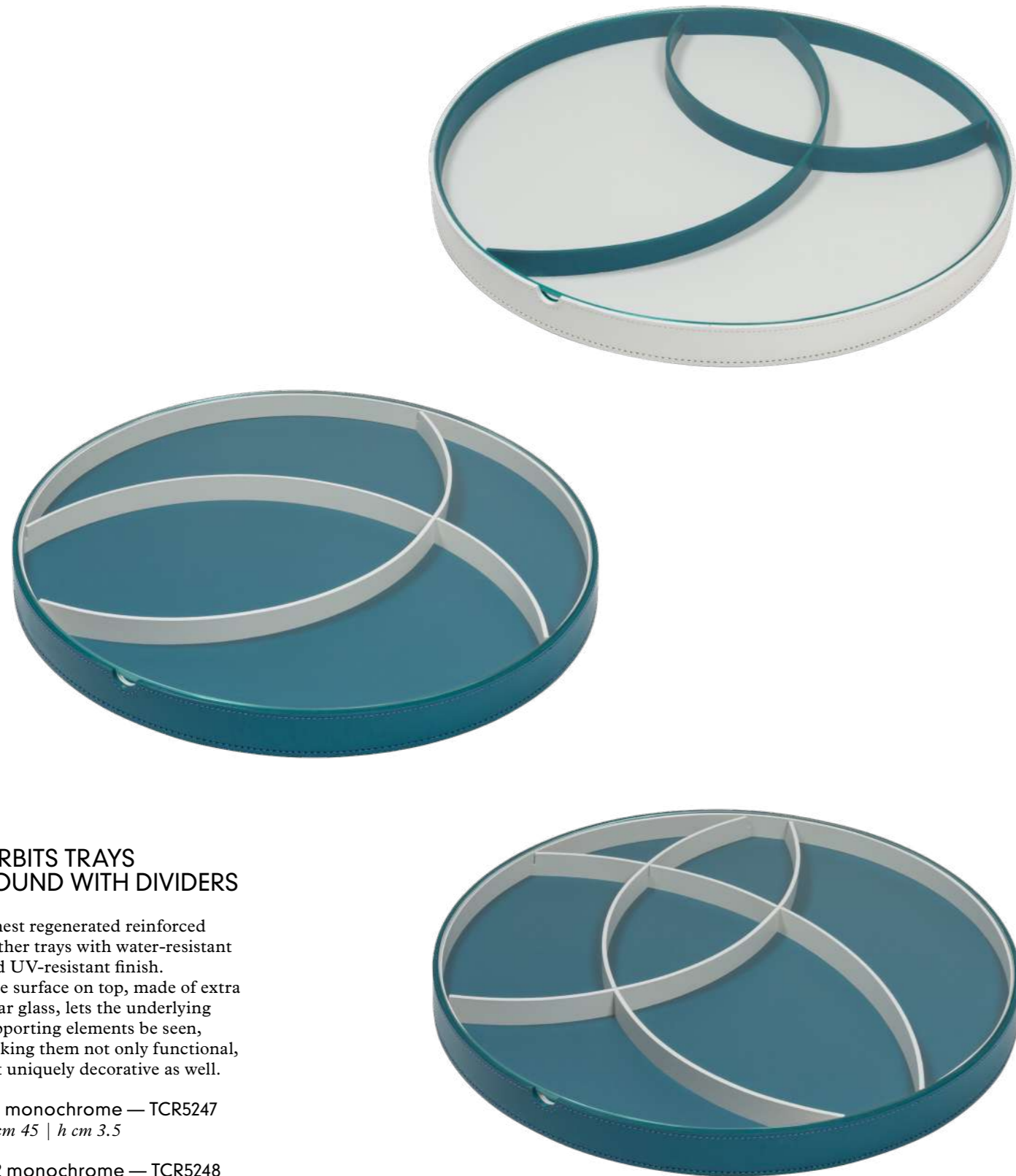

ORBITS TRAYS ROUND WITH DIVIDERS

Finest regenerated reinforced leather trays with water-resistant and UV-resistant finish. The surface on top, made of extra clear glass, lets the underlying supporting elements be seen, making them not only functional, but uniquely decorative as well.

n°1 monochrome — TCR5247
Ø cm 45 | h cm 3.5

n°2 monochrome — TCR5248
Ø cm 45 | h cm 3.5

n°3 monochrome — TCR5249
Ø cm 45 | h cm 3.5

n°1 bicolor — TCR5247BIC
Ø cm 45 | h cm 3.5

n°2 bicolor — TCR5248BIC
Ø cm 45 | h cm 3.5

n°3 bicolor — TCR5249BIC
Ø cm 45 | h cm 3.5

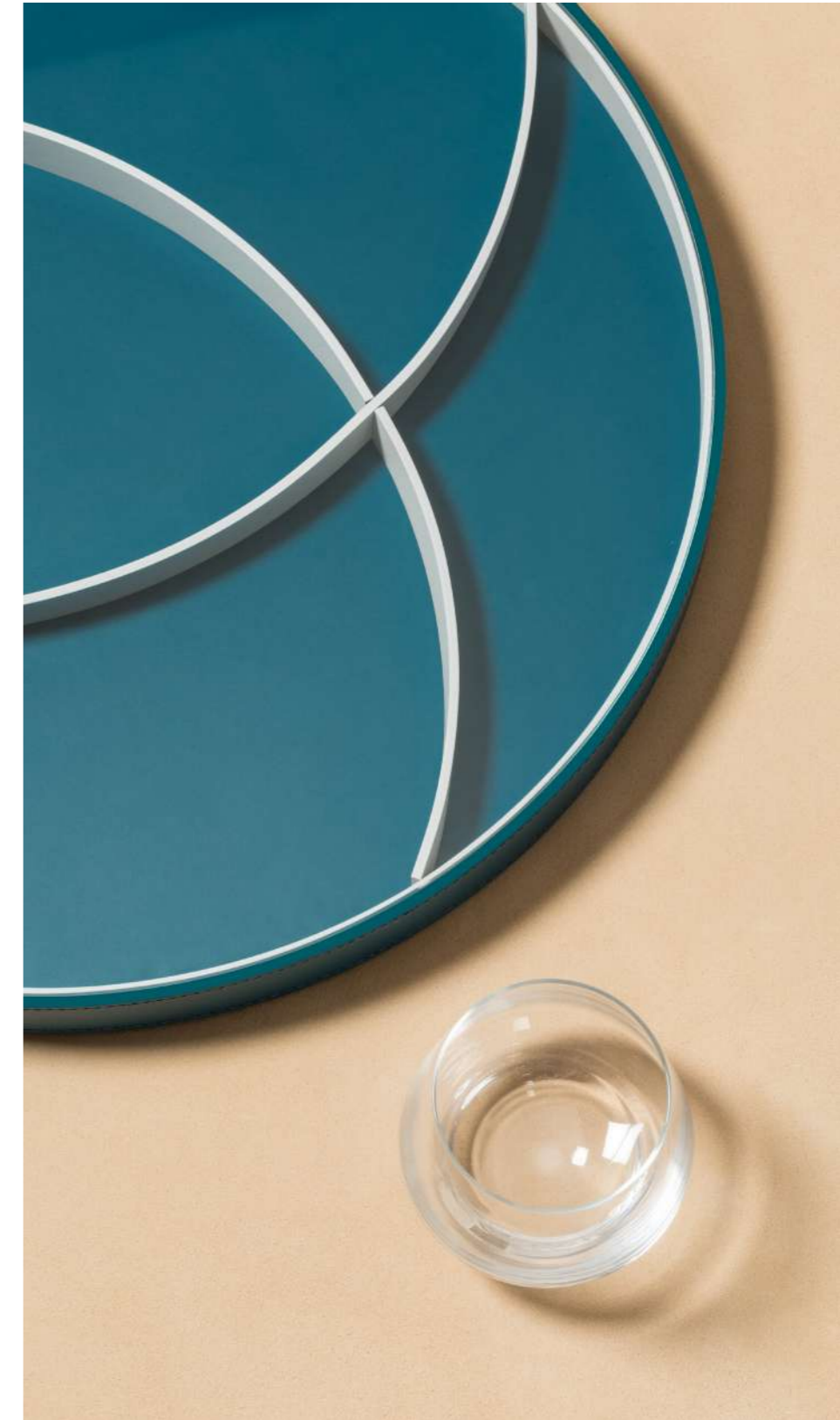

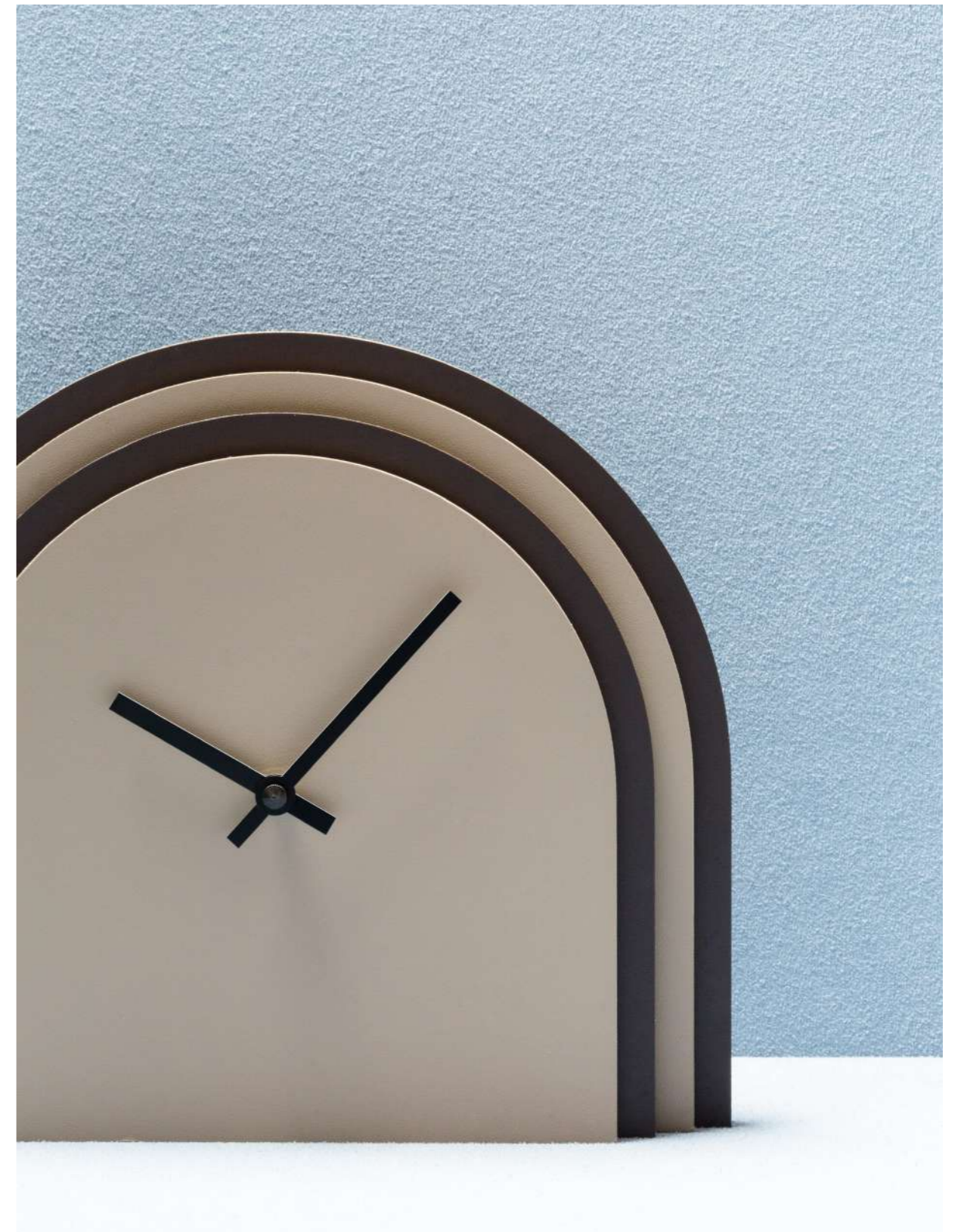



CENTRAL DESK CLOCK

Desk clock made of several overlaying sheets of Tecnocuoio®.

As a sort of miniature architectural element, it provides the shapes with rhythm and lightness by playing with color, repetition and shadows that generate between one layer and the other.

It is possible to choose any color combination from our chart for the bookend's bicolor version.

monochrome — TCR4001
cm 23 x 20 | h cm 5.5

bicolor — TCR4001BIC
cm 23 x 20 | h cm 5.5



AMPÈRE WIRELESS CHARGER

Fast wireless charger made with Tecnoquoio®, a finest regenerated leather with water-resistant and UV-resistant finish.
Suitable for all Qi-Enabled phones.
For a faster recharge is recommended to remove the phone case as it does not charge through metal/PU/ Bulky cases.
The phone has to be centered on the charging pad.
Includes USB type A cord (1.2 m) + mobile charger with 4 plugs: 2P Euro / BS / US / Australia-C.

monochrome — TCR4670
cm 26 x 13 | h cm 5

bicolor — TCR4670BIC
cm 26 x 13 | h cm 5





SPECTER CLOTHES HANGERS

Finest regenerated leather structure with water-resistant and UV-resistant finish. Two characterizing buttons keep the shoulder supports fixed together while granting personality to the piece.

monochrome woman — TCR5600
width cm 41

monochrome man — TCR5601
width cm 46

bicolor woman — TCR5600BIC
width cm 41

bicolor man — TCR5601BIC
width cm 46

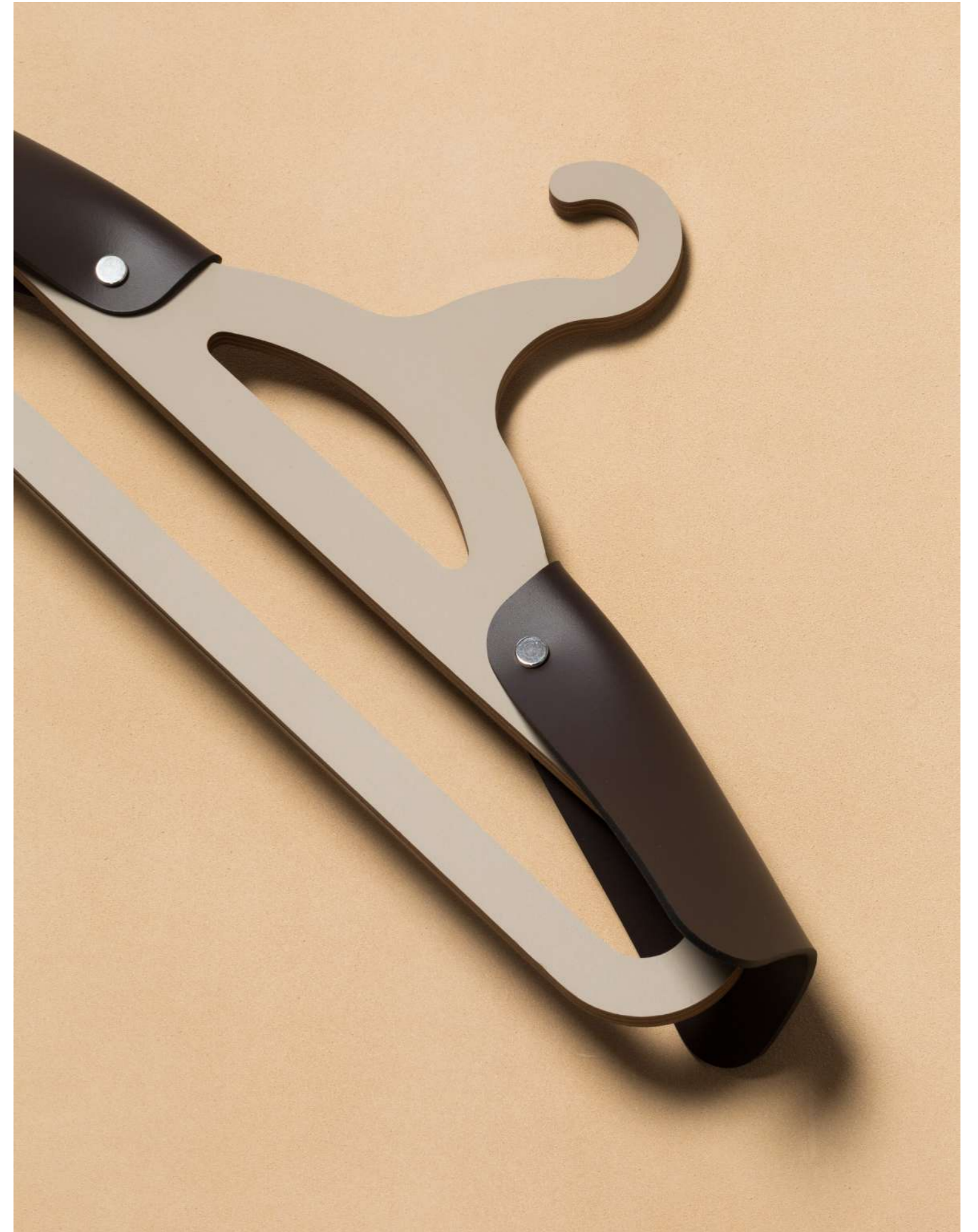

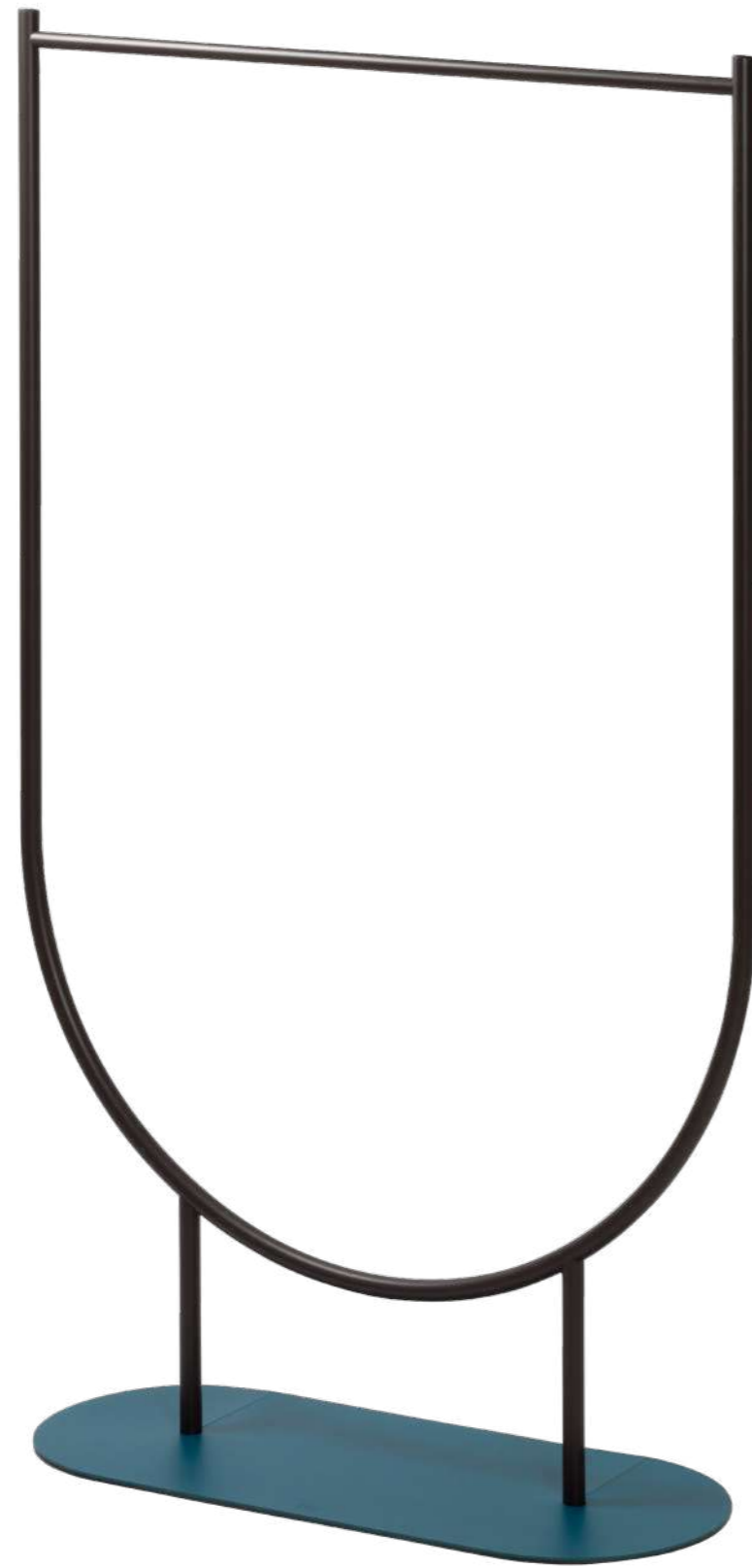

**MASK
CLOTHES VALET**

A clothes valet with self-supporting coated metal structure.
A finest regenerated leather cover with water-resistant and UV-resistant finish is applied on the base.

TCR9011
cm 95 x 35 | h cm 163







CIRCUIT BASKETS WITH DIVIDERS

Finest regenerated reinforced leather baskets with dividers, provided with water-resistant and UV-resistant finish. It features a characterizing dark-stained metal handle.

low with 3 dividers — TCR5935
cm 24 x 18 | h. cm 16

tall with 6 dividers — TCR5936
cm 27 x 12 | h. cm 26



FINISHES

CUSTOMIZATION

It is possible to provide products with an even more exclusive feeling requesting a debossed customization. Choose the stamps' sizes and to either apply or not a foil. Debossing foils feature a wide number of colors; the selection plays on endless associations and includes metallic finishes.



TECNOCUOIO®

Trademarked by the company in 1996, this innovative material is composed of 65% genuine leather castoffs tanned with vegetal extracts, 18% natural latex (extract from the rubber tree), 10% water, 5% natural fats and 2% natural coloring agents and salts. Rudi utilizes a production technique that adheres to a zero-waste philosophy that is eco-friendly and functional.

The result is a high quality regenerated leather boasting elasticity that is both UV-resistant and water-resistant and which features a perfectly smooth surface.

TECNOCUOIO®
finest regenerated leather

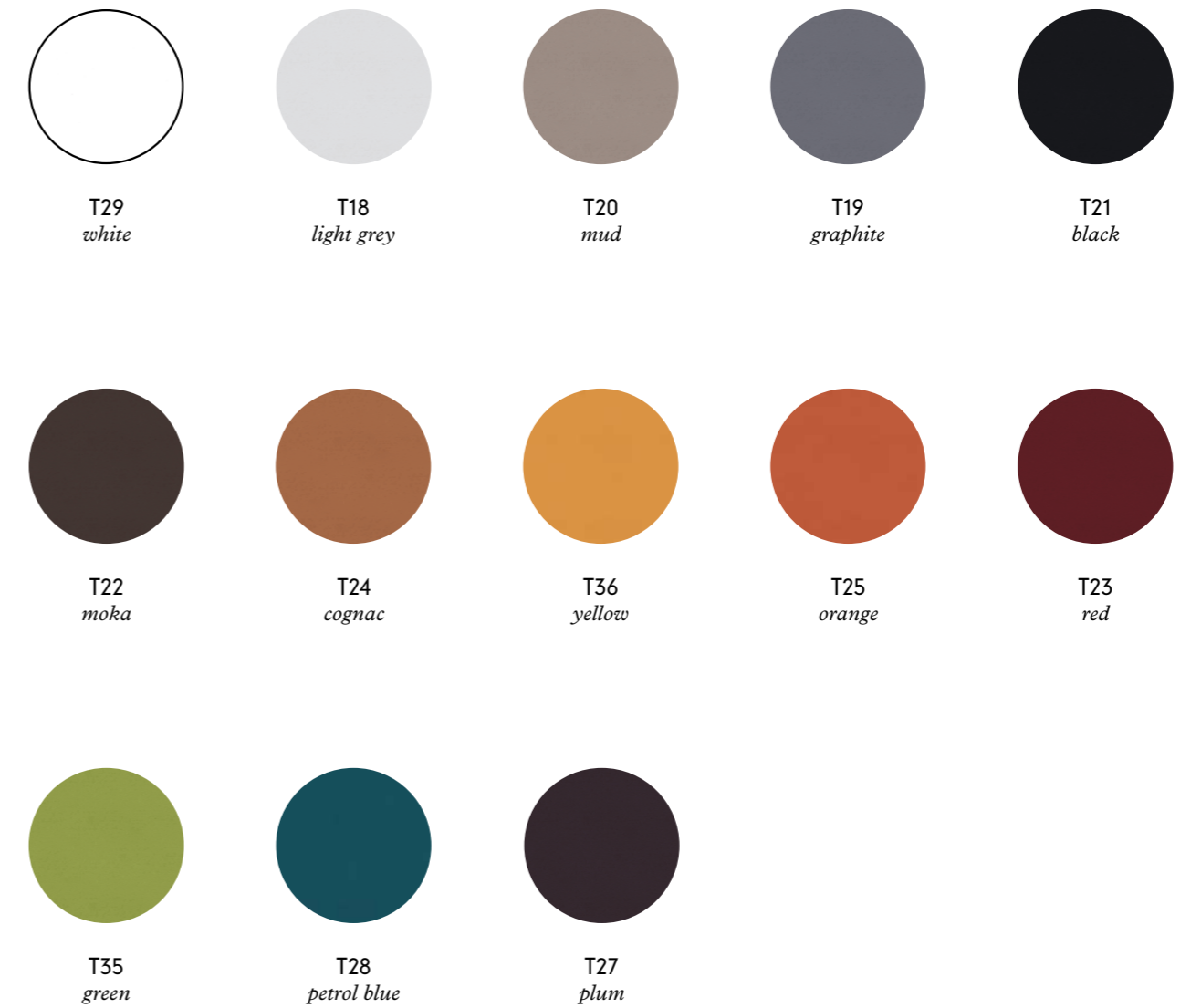



graphic design
Giobagnara studio

photography
Giobagnara studio

GIOBAGNARA

manufacture / headquarters

via Vivaldi, 12
16126 Genova — Italy
ph. cm +39 010 2518989

showroom

via Garibaldi, 12
16124 Genova — Italy

store

sestiere San Marco
calle delle Ostreghe, 2456/9
30124 Venezia — Italy

press contact

LFO_ Liza Fitoussi Office
contact@agencelfo.com
+33 (0)148 781528

www.giobagnara.com
info@giobagnara.com
instagram: @giobagnara